

# Ageing@home: A secure 5G welfare technology solution for elderlies

Boning Feng<sup>1</sup>, Birgitta Langhammer<sup>1</sup>, Van Thuan Do<sup>1,2</sup>, Niels Jacot<sup>2</sup>, Bernardo Santos<sup>1</sup>, Bruno Dzogovic<sup>1</sup>, Per Jonny Nesse<sup>3</sup>, Thanh van Do<sup>3,1</sup>

<sup>1</sup> Oslo Metropolitan University, Pilestredet 35, 0167 Oslo, Norway

<sup>2</sup> Wolffia AS, Haugerudvn. 40, 0673 Oslo, Norway

<sup>3</sup> Telenor ASA, Snarøyveien 30 1331 Fornebu, Norway

```
{boning.feng,birgitta,bersan,bruno.dzogovic}@oslomet.no  
{vt.do,n.jacot}@wolffia.net  
{per-jonny.nesse,thanh-van.do}@telenor.com
```

**Abstract.** The world population is ageing at a fast pace and to enable elderly to age at home can become a viable solution both economically and socially speaking, leading also to the overall improvement of the elderly's well-being and comfort. There are currently a few AAL (Ambient Assisted Living) systems which although operational are not yet optimal in terms of efficiency and security. This paper proposes a welfare technology solution called Ageing@home which aims at enabling newly hospitalized elderlies to come home earlier by making use of a dedicated 5G network slice for health care system. Such an isolated logical network will provide adequate security, privacy and reliability for the selected welfare technologies and services deployed at the elderly home. The proposed solution allows the selection and customization of needed welfare technologies and services and promotes the re-allocation and re-use of equipment. Validation methods and a business plan have been presented as well as a thorough description of a proof-of-concept implementation.

**Keywords:** 5G mobile networks, network slicing, assisted living, home based elderly care, welfare technology

## 1 Introduction

Ageing population is taking place across all countries of the world, raising major issues for the direction of social policy [1]. The proportion of those aged 60 years and older in the Global North is expected to reach 32% in 2050. In the Global South, the share of older persons increased slowly between 1950 and 2013, from 6% to 9%, but is expected to accelerate in the coming decades, reaching 19% in 2050 (United Nations, 2014a). This can lead to significant challenges such as increased dependency rates, overload of the healthcare systems, lack of elderly homes to provide support, etc. Enabling elderly

people to stay and live in the comfort of their own homes as much as possible is a good solution to address those problems, as it puts less pressure on the current healthcare systems and is by far more cost efficient than elderly homes. It is important nonetheless to be able to monitor the senior citizen's well-being and to provide appropriate guidance and assistance in this process. In Europe, the Ambient Assisted Living (AAL) Programme [2] has as an objective the development and use of new technologies to allow elderly and disabled people to live comfortably at home, improving their autonomy, facilitating daily activities, ensuring better security, monitoring and treating sick people. Similarly, in the Nordic countries including Norway, welfare technologies [3] have been proposed to provide better services for the elderly living at home and in nursing homes.

Unfortunately, the state-of-the art welfare technologies are still suffering from many major limitations [4], such as: operation instability, deployment difficulties, poor usability and high costs which hinder their adoption and use [5]. One of the root causes lies on the use of WLAN (Wireless LAN) as connectivity technology, which suffers of disadvantages like poor security, complex configuration, limited portability, dependency on electricity, etc. Indeed, it could be quite challenging at deployment to configure and obtain optimal connectivity with WLAN. To remedy the mentioned shortcomings, we propose Ageing@home, a 5G-based solution, which makes use of the concept of network slicing to provide simple and quick deployment, simple recollection and re-use of allocation of equipment and service adaptability and extensibility. This solution is a further refinement of Home-based Elderly Care solution realized at the Secure 5G4IoT lab in Oslo [6] which enables the elderly who just had an operation at hospitals to come home by tailoring and deploying technology equipment e.g., sensors, actuators, monitoring devices, etc. necessary for a remote follow-up and assistance by healthcare personnel. Network slices (dedicated logical networks) will be allocated to the Ageing@home solution to connect in a secure way all the health sensors, devices and all caregivers to the Health Care application running on the cloud. The proposed solution will ensure higher level of security and privacy while facilitating the caregiver's assistance to the elderly in need.

The paper starts with a brief summary of state of the art of digital solutions to smart living environments for ageing people. A brief introduction of the 5G mobile network slicing is included before the main part of the paper, which is the detailed description of the proposed Ageing@home solution. To validate the implementation of the proof-of-concept, validation methods are elaborated and described in the following section. Next is the business plan which aims to ensure the successful adoption of Ageing@home as well as the description of the proof-of-concept implementation at the Oslo Metropolitan University's Secure 5G4IoT lab. To conclude, the paper presents some final remarks with some suggestions for future works.

## 2 State of the art of digital solutions to smart living environments for ageing people

There are currently many research activities both in EU and the Nordic countries. As umbrella programmes there are Active & Assisted Living (AAL) programme, a European Innovation Partnership with 19 countries and Nordic Ambient Assisted Living coordinated by the Nordic Council of Ministers. In addition to numerous national projects in European countries there are also multiple COST and H2020 projects such as Sheld-on, Activage, Phara-on, Ghost-IoT, etc. Unfortunately, so far, the AAL Digital solutions has still quite low uptake due to the following limitations:

- **Low technology maturity** [7]
  - o *Instability*: Most solutions using Wireless LAN 802.11 experience occasional loss of connection due to interference, channel collision, coverage variation, etc.
  - o *Configuration problems*: The usage of Wireless LAN also requires the configuration of several parameters for each installation, which is error prone. Further, security protection requires considerable knowledge and efforts.
  - o *Installation difficulties*: The installation of sensors and devices at the elderly home could be difficult due to the furniture, time consuming and hence annoying to the users.
- **Fragmentation**: The current digital solutions are “silos” applications that operating in isolation without interworking and interoperability with each other. Consequently, the introduction of additional services will require a full installation of hardware and software which incurs high cost and disturbance to the elderly
- **Technology oriented**: The current digital solutions are too much technology oriented [8] consisting of a bunch of technologies that are put together and offered to the elderly without sufficient considerations of the elderly user preferences or the health personnel’s opinions [9].
- **Security and Privacy issues**: Although it is necessary to collect data to provide effective services to the elderly these data are personal which illegal access constitutes a privacy violation [10]. Unfortunately, the protection of personal data is currently not adequate. Further the use of video camera has been considered as obtrusive by elderly who feels watched.

## 3 Brief introduction to 5G network slicing

The 5th generation mobile network (5G) [12] is well known for its significant advantages compared to 4G in terms of performance, coverage and quality of service and the promise of an enhanced mobile broadband (eMBB) with higher data speed and the support of a wide range of applications and services ranging from massive machine-type communications (mMTC) to ultra-reliable and low-latency communications (URLLC). Less known but not less important is the fact that 5G is a softwareized and virtualized network [13].

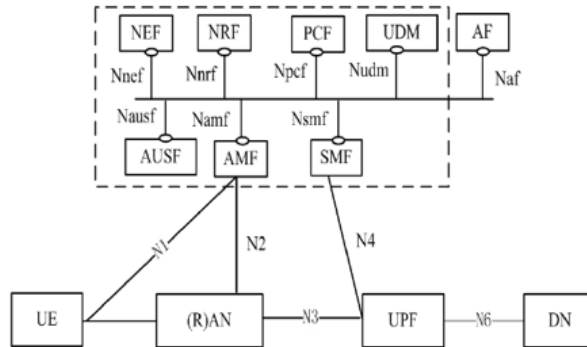

**On the User plane:**

- **UE** (User Equipment): is the user's mobile phone.
- **(R)AN** (Radio Access Network): is the Access Network Function which provides connectivity to the mobile phone.
- **UPF** (User Plane Function): handles the user plane traffic, e.g., traffic routing & forwarding, traffic inspection and usage reporting. It can be deployed in various configurations and locations depending on the service type.
- **DN** (Data Network): represents operator services, Internet access or 3rd party services.

**On the Control plane:**

- **AMF** (Access and Mobility Management Function): performs access control, mobility control and transparent proxy for routing SMS (Short Message Service) messages.
- **AUSF** (Authentication Server Function): provides authentication functions.
- **UDM** (Unified Data Management): stores subscriber data and profiles. It has an equivalent role as HSS in 4G but will be used for both fixed and mobile access in 5G core.
- **SMF** (Session Management Function): sets up and manages the PDU session according to network policy.
- **NSSF** (Network Slice Selection Function): selects the *Network Slice Instance (NSI)*, determines the allowed *network slice selection assistance information (NSSAI)* and AMF set to serve the UE.
- **NEF** (Network Exposure Function): exposes the services and capabilities provided by the 3GPP network functions.
- **NRF** (NF Repository Function): maintains NF profiles and supports service discovery.
- **PCF** (Policy Control function): provides a policy framework incorporating network slicing, roaming and mobility management and has an equivalent role as PCRF in 4G.
- **AF** (Application Function): interacts with the 3GPP Core Network (CN) to provide services

**Figure 1 The 5G Reference Architecture (Courtesy of 3GPP)**

The software nature of the 5G network brings with it both weaknesses and strengths since it shows the same vulnerabilities as any other software at the same time as higher flexibility and dynamicity can be achieved through the logical network segments also known as Network slices.

Currently, there is no consensus on what a network slice is and how it can be realized [14]. In fact, while the 3rd Generation Partnership Project (3GPP) [15] provides a more network-focused definition stating that “network slices may differ for supported features and network functions optimizations”, the 5G Infrastructure Public Private Partnership (5G PPP) adopts a business oriented view mandating that “a network slice is a composition of adequately configured network functions, network applications, and the underlying cloud infrastructure (physical, virtual or even emulated resources, RAN resources etc.), that are bundled together to meet the requirements of a specific use case, e.g., bandwidth, latency, processing, and resiliency, coupled with a business purpose [16].

In this paper we use the 5G PPP's definition that allows the support of a variety of devices. To obtain a wireless Home Networking capable of supporting a broad range of devices, the 5G network slicing concept is adopted to establish a secure 5G network for Elderly Care.

## 4 The Ageing@home solution

### 4.1 Objectives

The main objective of Ageing@home is to enable newly hospitalized elderly to return home earlier by providing a set of welfare technologies and services deployed at their home which provides efficient support and assistance from the healthcare personnel. Ageing@home solution can also be used permanently or temporarily for the time needed towards full recovery. The deployed equipment could be easily removed and recollected for re-use by other elderly. As such, Ageing@home can be used in a dynamic and customized way for any elderly who needs assistance from healthcare personnel while living at their home.

### 4.2 Ageing@home welfare technologies and services

The Ageing@home solution is adaptable and can be tailored to fit the demands of each individual elderly by enabling the selection and customization of the following welfare technologies and services:

- **Vital Signs Monitoring System:** allows the monitoring of vital signs such as heart rate (HR) [17], body temperature (BT), respiration rate (RR) and blood pressure (BP), etc. that are used by the medical professionals to get a good overview about the health of the elderly person.
- **Reminding System:** helps elderly citizens remembering to take their medicines as well as meals at correct time and dosage [18].
- **Automated Activity and Fall Detection System:** can distinguish between normal and abnormal activities and to detect a fall to trigger an alert, which can again result to an emergency with intervention of caregivers [19].
- **Automated Emergency Call System:** locates, contacts and directs the nearby appropriate caregiver who gives assistance to the elderly person in emergency cases [20].
- **Multimodal Communication:** provides secured remote medical check-up call with doctor/medical staff, secured interactions with health care system including notifications and alarms at the same time as it helps to combat isolation and loneliness by allowing elderly to communicate to friends and relative.

### 4.3 Typical use case

To illustrate the flexibility, adaptability and scalability of Ageing@home let us consider the case of Kari who had a successful heart surgery and is allowed to come home after 4 days instead of one week on the condition that her vital signs, glucose and breathing status are monitored and also assistance can be given on time at occurrence of incidents such as loss of consciousness, fall, heart attack, etc. In addition, Kari suffers of sleep

disorder which needs to be diagnosed. Last but not least, Kari needs a secure communication facility which allows secure interactions both with the hospital and also with her family and friends.

To be safe at home, Kari will need to have the following technologies in place at her home:

- Sensors for monitoring of vital signs, glucose and breathing
- Sensors for detection of incidents such as loss of consciousness, fall, heart attack, etc.
- A tablet PC acting as a secure communication with the hospital and for contact with family and friends
- A secure and reliable connection to link the sensors and equipment to the hospital system

As the majority of elderly, Kari does not have the necessary sensors and equipment nor the secure and reliable connection needed. But, thanks to Ageing@home all the necessary equipment and infrastructure can be identified, allocated, configured and installed at Kari's home short time before her return. The roll out consists of the following steps:

- Visit and assessment of the technology infrastructure at Kari's home by technology specialists
- Design and configuration of the necessary equipment such that they will be functioning immediately after power on without any on-site configuration:
  - 5G Sensors and devices will get installed SIM cards. The device/sensors IDs, the corresponding IMSIs (International Mobile Subscriber Identity), the corresponding ISDNs (Mobile Station International Subscriber Directory Number) will be registered and their access rights to the healthcare 5G network slice (will be described in later section) and to the healthcare system will also be set up and enabled.
  - For sensor and devices using other wireless technologies such as Bluetooth, Zigbee, WLAN, etc. 5G gateway will be used and necessary pairing to ensure security will be performed.
- Design and establishment of the connection to the Health care network slice: Depending on the availability of broadband connection at Kari's home, one connectivity alternative will be chosen among 5G Fixed-wireless Access (FWA), indoor radio unit or 5G enhance Mobile Broadband.

#### 4.4 Conceptual architecture

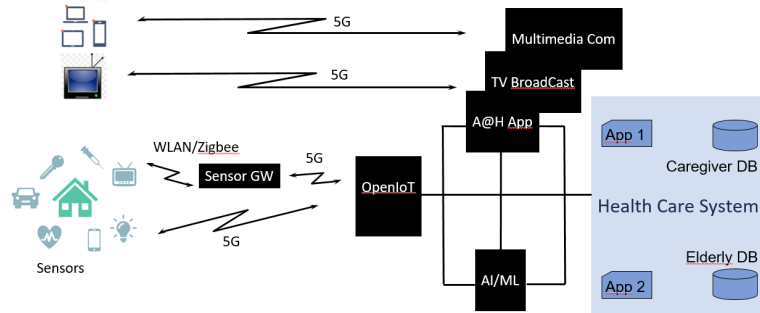

**Figure 2 The Ageing@Home conceptual model**

To be able to accommodate all the improved welfare technologies described above in a customized, adaptable and scalable way the Ageing@Home end-to-end solution has an architecture represented by a conceptual model shown in Figure 2.

Multiple heterogeneous sensors, both wearable aka on-body and ambient aka off-body with dedicated mission are connected to an open unifying IoT platform (OUIP) directly via 5G or indirectly, first via certain Local Area technologies such as Wireless LAN IEEE 802.11x, Zigbee, Z-wave, etc., to a Sensor Gateway and then via 5G to the OUIP. The sensors collect data and upload to the OUIP, which can then forward the collected data depending on the need to the Ageing@Home applications (Ageing@Home Apps), the Artificial Intelligence/Machine Learning (AI/ML) Platform or the Health Care System (HCS), where they are consumed in various ways. At the AI/ML Platform, the data are in multiple analytic tasks, especially the elaboration of the elderly's profile, which allows for better understanding and to respond appropriately to their needs and moods. When necessary, the data can be anonymized before being forwarded and stored.

The AI/ML Platform has interfaces with the Ageing@Home Apps and the HCS, which are then enabled to invoke various analytic tasks. The interface between the Ageing@Home Apps and the HCS enables the Ageing@Home Apps to access the HCS user and caregiver database and also other functionality, while the HCS can control the Ageing@Home Apps. The Ageing@Home Apps are essential to the implementation and provision of the targeted welfare technologies such as Digital night vision, Entertainment, Event and vital sign monitoring and detection, etc. Two Ageing@Home Apps, Broadcasting of Physical exercises and Multimodal communication, as communication apps have direct connection with their devices, i.e. TV, PC, tablets, etc.

#### 4.5 The 5G Healthcare network slicing

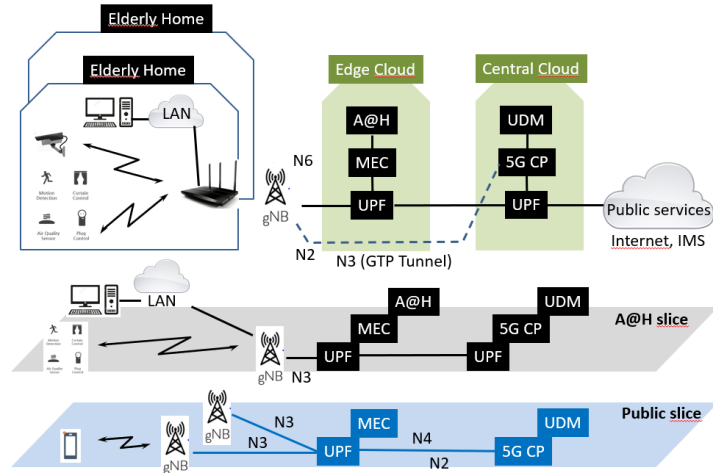

**Figure 3 Network Slicing for Ageing@home**

In order to provide a connection which provides adequate protection of security and privacy at an acceptable level of reliability, a dedicated and isolated end-to-end network slice will be established. This healthcare network slice is a logical network realised by own vNFs (Virtual Network Functions) for both access network and core network as shown by Figure 3. Only devices equipped with SIM cards own by the hospital can be authorised to connect to this healthcare network slice. While IoT devices are in general not allowed to, some smartphones may be permitted to have simultaneous connection to the public network slice depending on the security policy of the hospital.

As shown in Figure 3, the Ageing@Home solution consisting of OUIP (open unifying IoT platform), AI/ML (Artificial Intelligence/Machine Learning) platform and a variety of Ageing@Home applications are hosted on a MEC (Multi-access Edge Computing) host, which is located on Edge Cloud. Since the Edge Cloud is in the same area as the elderly home, very low latency can be achieved making this deployment option quite suitable for Welfare technologies, such as Broadcasting of physical exercises and mobility sessions technology. Further, both the security and privacy are considerably enhanced because communications between sensors and the Ageing@Home do not have to traverse the entire mobile network, but only a short path between the gNBs and the Edge Cloud.

## 5 Validation methods

To be accepted and used it is crucial that the Ageing@Home solution not only technically functions properly but also meets all the needs and demands of the elderlies as primary users and the health care personnel as secondary users. For the technical



functioning, thorough functional and performance testing will ensure the proper operation of the Ageing@Home solution.

Regarding the user acceptance it is far more challenging and not quite successful for existing welfare technologies. For example, while giving positive answers when being asked about the use of cameras in monitoring and assistance service some elderlies sabotaged the cameras by disconnecting them or taping over the lens.

Ageing@Home will make use of a combination of most efficient existing validation methods while researching and experimenting new ones as follows:

- *Outcome measures*: to measure some aspects and benefits
- *Use monitoring*: to have an overview of the use of the digital solution, which proves their usefulness
- *Questionnaires*: to gather information from a wider group of users
- *Interviews*: to collect information from selected users. By using a structure of questions and open-ended questions it is possible to capture issues that escaped the other measurements.

## 5.1 Outcome measures

### • Independence

**The Lawton Instrumental Activities of Daily Living Scale (IADL)** is an appropriate instrument to assess independent living skills (Lawton & Brody, 1969) [21] and is useful for identifying how a person is functioning at the present time and for identifying improvement or deterioration over time.

There are 8 domains of function measured with the Lawton IADL scale: ability to use the phone, shopping, food preparation, housekeeping, laundry, mode of transportation, responsibility for own medications and ability to handle finances. Persons are scored according to their highest level of functioning in that category, scores ranging from 0 to 1. A summary score ranges from 0 (low function, dependent) to 8 (high function, independent).

### • Quality of Life /Health Related Quality of Life

Health related quality of life (HRQoL) refers to how health impacts on an individual's ability to function as a multi-dimensional concept that includes domains related to physical, mental, emotional, and social functioning. A related concept of HRQoL is well-being, which assesses the positive aspects of a person's life, such as positive emotions and life satisfaction.

The RAND-367 [22] is a 36-item questionnaire intended for use as a generic measure of HRQoL. It is developed by a non-profit organization RAND Corporation and the 36 items are identical to SF-36, described by Wade and Sherbourne (1992).

## 5.2 Use Monitoring

The usefulness and usability are best proven by the use of the proposed solution. For that, the Ageing@Home solution will have embedded log function which allows to record how often it is used. This method may not be usable in cases in which sensors and devices or services are constantly used.

### 5.3 Questionnaires and interviews

The success of the questionnaires and interviews relies totally on the asked questions and on the views and perspectives they are focused on. So far, the sociological perspective is still neglected, and Ageing@Home project will remedy the situation by carrying out innovative research on relational perspectives on gerontechnology, i.e. technology for old age which encompasses three central dimensions:

1. The relationship between care and control
2. The relationship between autonomy and social isolation
3. The question of agency's relation to rationality, emotion and habits

## 6 Business plan

To ensure the success and adoption of Ageing@home, it is essential to have a sound commercial exploitation. A business plan must be elaborated at early stage and populated gradually with more details. The latest version of the Ageing@home business plan is shown in Table 1.

<b>Ageing@Home Business Plan</b>
<b>Vision:</b> to secure smart living environments for ageing and disabled people enabling them to live a secure and comfortable life at home as long as possible.
<b>Mission:</b> to develop and launch a customizable and scalable end-to-end digital solution using multiple welfare technologies that offers different services to elderly people living at home. The Ageing@Home solution shall mitigate the limitations with current welfare solutions for elderly, improve the operation instability and deployment difficulties for caretakers and represent a more efficient use of resources/cost decrease for the nurseries and the municipalities.
<b>Products/ Service Solution:</b> Ageing@Home is an extensible and customised solution which enable the selection and customisation of the following welfare technologies as described earlier: <ul style="list-style-type: none"><li>• Event and vital sign monitoring and detection<ul style="list-style-type: none"><li>○ Basic system for abnormality detection and appropriate response</li><li>○ Action recognition and prediction system</li><li>○ Improved digital remote passive attention</li><li>○ Long term sleep status monitoring</li><li>○ Behaviour analysis system by sound, voice and communication</li></ul></li><li>• Reminding System</li><li>• Multimodal communication</li><li>• Automated Emergency Call System</li></ul>
<b>Customers/Market:</b> <ul style="list-style-type: none"><li>• <b>Primary users</b> of Ageing@Home solutions are elderly living at home</li><li>• <b>Secondary users</b> are healthcare personnel supporting and interacting with the elderly in their home location. Retirement homes/nursing homes may also make use of the Ageing@Home solutions. The primary and secondary users are invited to participate in workshop and demonstrations and giving feedbacks on the different solutions versions.</li></ul>

- **Other Ageing@Home stakeholders:** Municipalities in charge of eldercare in Nordic countries and healthcare organizations in other countries are both decision makers in relation to deciding which eldercare solutions to purchase and implement. In addition, elderly organizations, relatives of elderly, national health authorities are also relevant stakeholders with interests in the outcome from the project. Providers of elderly solutions such as telecom operators, Internet service providers, device/terminals providers also have interest in the project outcome.
- **Market:** Population ageing is taking place across all countries of the world, raising major issues for the direction of social policy. The proportion of those aged 60 years and older in the Global North is expected to reach 32% in 2050. In the Global South, the share of older persons increased slowly between 1950 and 2013, from 6% to 9%, but is expected to accelerate in the coming decades, reaching 19% in 2050 (United Nations, 2014a). According to EU, they estimate a doubling of elderly over 80 years from 5% in 2015 to 12% in 2060. Moreover, the ratio of workers to pensioners will decrease with 50% from four workers per pensioner in 2015 to 2 workers per pensioner in 2060 [23]

**Organization and Management:**

The following work after validation of the Ageing@Home solution during the pilot tests is the launch and go to market activities. Telenor as main partner of Ageing@home plans to be the actor that offers an integrated end-to-end Ageing@Home solution to the municipalities. In Norway and the Nordic market (Norway, Sweden, Denmark and Finland), this offering will be aligned with existing portfolio on welfare technology solutions.

Ageing@Home solution features based on inventions, design or other intellectual work developed by sub providers related to the integrated offering from Telenor will follow an application process for IP protection managed by the responsible party in parallel with piloting and go to market process.

**Go to market plan/Action plan:**

The major industry partners in the consortium will head their go to market plans for their respective geographical market segments. For these market segments the following actions will be executed:

- **Demonstrations and promotions:** There will be presentations of the pilots and results in Norway and internationally. National demonstrations of the pilots will be carried out at Norwegian National health conferences arranged by KS and the yearly e-Health conference by Norsk Helse IT together with Nordic e-health conference [24].
- **Dissemination materials** will be brochures, posters and flyers elaborated and distributed at the demonstrations. Results from the pilots in Norway and Portugal will be planned to be demonstrated in selected EU e-Health related events, conferences, workshops and exhibitions throughout year 3 such as European conference an exhibition namely Mobile World Congress and Nordic Conference on ICT.
- **Sales targets:** The market objective after launching the commercial Ageing@Home solution is to secure adoption by 25% of the roughly 250 municipalities in Norway that remains implementing Telenor's welfare technology. Whether the target is met will be measured three years after the Ageing@Home is deployed. The Ageing@Home solution will be launched in the other Telenor Nordic subsidiaries Denmark, Sweden and Finland

<p>with the same 25% target market share of the solution in municipalities. Altice and Cisco plans for similar sales strategies in their respective market segments.</p> <ul style="list-style-type: none"> <li>• <b>Pricing strategy:</b> A fixed price for the different unified Ageing@Home solution features as well as a fixed price for the unified Ageing@Home solution including all the features. Complementary services such as training, customization, implementation, maintenance, certification and support services will be priced extra based on a combination of penetration pricing, value-based pricing and variable pricing strategies. Prices will be evaluated and determined through the project execution.</li> </ul>
<p><b>Financing and funding:</b></p> <p>The detailed business plan from the will be developed during the project execution including estimated costs and revenues over a two to three-year period for all activities necessary to perform the further development, produce and deliver the Ageing@Home product/service for the specific Nordic, EU target markets. Required amount of funding (money and competence/persons wise) to finance (Capex/Opex) these activities will be described together with funding sources.</p> <p>The industry partner Telenor will together with their subproviders finance the commercialization and go to market activities. There are however options for SME/Sub providers to acquire funding of further development and testing activities in relation to pilot customers [25] as well as for commercialization activities [26] with help from public agencies such as Innovation Norway in Norway.</p>

**Table 1 Ageing@home business plan**

## 7 Proof-of-concept implementation

The network slicing for Ageing@home is achieved in a way that the users connecting to different slices will be isolated from each other and the WAN using policies and routing on-demand. In other words, separate users from slices that are not related to the healthcare system will not be able to connect to it without appropriate policies and authentication. In other case, this would open a security vulnerability that would enable adversaries to perform attacks within the slice or across network slices of the healthcare system.

Consequently, to avoid illegal actions and mitigate initial security threats, the Healthcare slice must be entirely separated from other slices, or more specifically the public enhanced Mobile Broadband slice for regular mobile communication. This implies that mobile network subscribers shall be denied access to the Healthcare slice and the assets and facilities related to it.

To complete the prerequisite, a detailed limiting network policy must be initiated at Core Networks and the C-RAN, aiming at constraining access to certain network end-points and permitting only approved traffic.

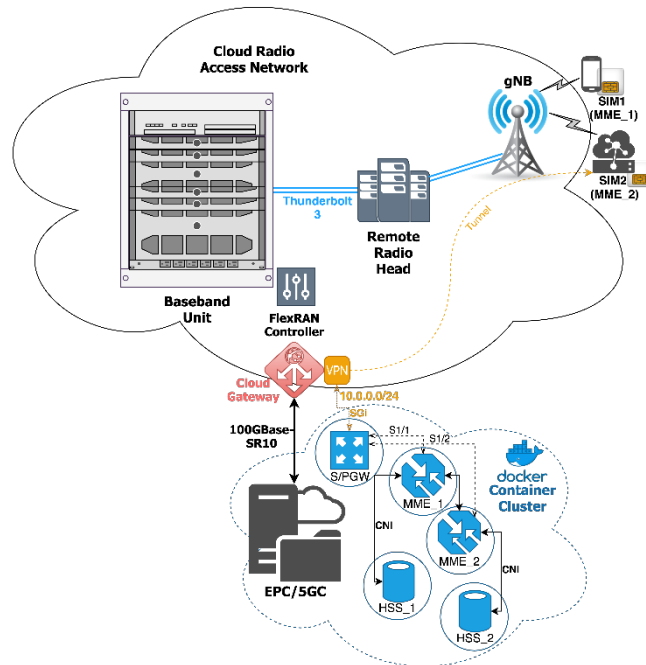
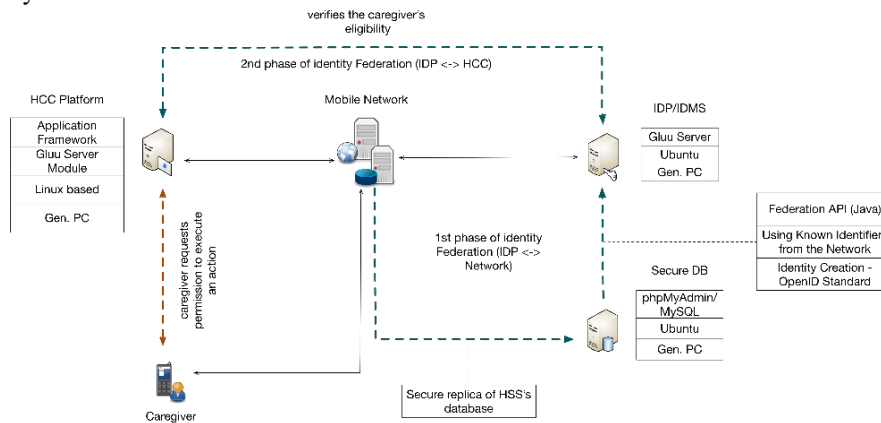

**Figure 4 5G4IoT Lab Cloud Radio Access Network slicing concept**

As represented in Figure 4, a 5G network infrastructure provisioned at the Secure 5G4IoT Lab, comprised of a Cloud Radio Access Network (C-RAN), is communicating to a cloud OpenAirInterface [27] vEPC (virtual Evolved Core Network). The deployment represents a functional split of a Baseband Unit (BBU) and the Remote Radio Heads (RRH), with the NGFI (Next Generation Fronthaul Interface). For network slicing, the User Equipment with SIM<sub>1</sub> is coupled to the Mobility Management Entity MME<sub>1</sub> instance, and the IoT apparatus using SIM<sub>2</sub> is associated with the MME<sub>2</sub>. Both MMEs are running into Docker containers as means of virtualization and define the virtual EPC core. The other core network functions follow the same virtualization principle, with two HSS (Home Subscriber Server) databases, or more precisely HSS<sub>1</sub> and HSS<sub>2</sub> that communicate with MME<sub>1</sub> and MME<sub>2</sub> instances, respectively. The container network interface policy restricts the communication between the two HSS instances and allow only their equivalently associated MME instances to execute DIAMETER authentication in adjacent PLMN (Public Land Mobile Network) domains. Through a VPN tunneled communication, the IoT devices with SIM<sub>2</sub> can have a secure access to the analogous network slice via its assigned SGW (Serving Gateway) and PGW (Packet data network Gateway), establishing a route to the adjoining MME<sub>2</sub> and a PLMN with identifier that classifies that MME. The Service and Packet Gateways enable virtual GTP-U (GPRS Tunneling Protocol User data tunneling) tunnels between the interface of the instance to a virtual interface at the MME<sub>1</sub> and MME<sub>2</sub>

successively, allowing the UE (User Equipment) to have a unique IP address and connectivity to the WAN and Internet.

The association of specific users to a specific network slice is achieved at the RAN layer, namely using the FlexRAN controller to match a particular IMSI (International Mobile Subscriber Identity) value of the UE to entries within the HSS\_2. When the UE authenticates with the network, the UEs will not be able to reach other devices that are authenticated in the HSS\_2, as these values are explicated in the HSS\_1 and the routes are thus different for the traffic to reach the WAN via distinct Service and Packet Gateways.



**Figure 5 Implementation of the Identity Management system**

Allied to the described network, an identity provisioning and management system (IDMS) [28] has been implemented as shown in Figure 5, to strengthen as well as simplify the authentication process for users (e.g. caregivers) and devices using the network by offering a single sign-on mechanism across the network and the application layers. More precisely, we inherit existing components from the network that can provide a secure way to identify a device and used it a unified way between layers.

To achieve a consensus on which parameters can be used as identifiers (**identity federation**), an API was also developed [29] to bridge between the IDMS and the network. After issuing the identities for the desired caregivers/devices, a module is created and given to the healthcare center, so that when a verification request has to occur, the healthcare center will confirm with the system as if one is eligible to provide support to an elderly person.

This identity management system is created by using an instance of the Gluu Server [30] that provides a combination of the provisioning and management tools, as well the option of deploying OpenID clients for integrations with third-party applications.

## 8 Conclusion

In this paper we have presented Ageing@home a welfare solution which enables newly hospitalized elderly to come home earlier by providing a secure, privacy preserving and reliable 5G network slice and an extensible and adaptable framework allowing the selection and customization of the needed welfare technologies and services. The solution also enables the re-allocation and re-use of equipment when they are no longer needed. Validation methods and business plan are elaborated in the preparation for a future trial.

The next step of this initiative is to carry out a field trial with real elderly users living in some municipalities in Norway. Although the current proof-of-concept is working only functional and limited performance tests have been done, further tests and validations done with real users must be performed to identify weaknesses that can be improved ensuring the adoption of Ageing@home for the benefits of the elderly. The most optimal validation would be a field trial with a limited set of elderly at one or two municipalities for a period of 6-12 months on a real 5G mobile network which is made available by the H2020 5G VINNI's facility pilot [31] in Norway. For the realization of such trial funding is required and efforts have been put to elaborate both national applications and EU project proposals. In addition, contacts and dissemination activities towards elderly organizations and municipalities should also be pursued.

## ACKNOWLEDGEMENT

This paper is a result of the H2020 CONCORDIA project (<https://www.concordia-h2020.eu>) which has received funding from the EU H2020 programme under grant agreement No 830927. The CONCORDIA consortium includes 23 partners from industry and other organizations such as Telenor, Telefonica, Telecom Italia, Ericsson, Siemens, Airbus, etc. and 23 partners from academia such as CODE, university of Twente, OsloMet, etc.

## 9 References

1. United Nations, Department of Economic and Social Affairs, Population Division (2017). World Population Ageing 2017 (ST/ESA/SER.A/408)
2. <http://www.aal-europe.eu/>
3. Velferdsteknologi - [https://www.helsedirektoratet.no/rapporter/implementering-av-velferdsteknologi-i-de-kommunale-helse-og-omsorgstjenestene-2013-2030/Implementering%20av%20velferdsteknologi%20i%20de%20kommunale%20helse-og%20omsorgstjenestene%202013-2030.pdf/\\_attachment/inline/cf340308-0cb8-4a88-a6d7-4754ef126db9:6f3a196c2d353a9ef04c772f7cc0a2cb9d955087/Implementering%20av%20velferdsteknologi%20i%20de%20kommunale%20helse-og%20omsorgstjenestene%202013-2030.pdf](https://www.helsedirektoratet.no/rapporter/implementering-av-velferdsteknologi-i-de-kommunale-helse-og-omsorgstjenestene-2013-2030/Implementering%20av%20velferdsteknologi%20i%20de%20kommunale%20helse-og%20omsorgstjenestene%202013-2030.pdf/_attachment/inline/cf340308-0cb8-4a88-a6d7-4754ef126db9:6f3a196c2d353a9ef04c772f7cc0a2cb9d955087/Implementering%20av%20velferdsteknologi%20i%20de%20kommunale%20helse-og%20omsorgstjenestene%202013-2030.pdf)
4. Woll, A. (2017). Use of Welfare Technology in Elderly Care. <https://www.duo.uio.no/handle/10852/55537>

5. Holthe, Torhild; Casagrande, Flavia Dias; Halvorsrud, Liv; Lund, Anne (2018). The assisted living project: a process evaluation of implementation of sensor technology in community assisted living. A feasibility study. *Disability and Rehabilitation Assistive Technology* 15(1):1-8
6. Boning Feng, Van Thuan Do, Niels Jacot, Bernardo Santos, Bruno Dzugovic, Ewout Brandsma, Thanh van Do: Secure 5G Network Slicing for Elderly Care, LNCS 11673, Proceedings of the 16th International Conference on Mobile Web and Intelligent Information Systems, MobiWis 2019, ISSN 0302-9743 ISBN 978-3-030-27191-6 ISBN 978-3-030-27192-3 (eBook), <https://doi.org/10.1007/978-3-030-27192-3I>, pp 202-216, Istanbul, Turkey, 26-28 Aug. 2019
7. Smart homes and home health monitoring technologies for older adults: A systematic review. Liu et al; <https://doi.org/10.1016/j.ijmedinf.2016.04.007>
8. Ambient Assisted Living Healthcare Frameworks, Platforms, Standards, and Quality Attributes - Mukhtiar Memon, Stefan Rahr Wagner, Christian Fischer Pedersen, Femina Hassan Aysha Beevi, Finn Overgaard Hansen. *Sensors (Basel)* 2014 Mar; 14(3): 4312–4341. Published online 2014 Mar 4. doi: 10.3390/s140304312
9. They Don't Care About Us! Care Personnel's Perspectives on Ambient Assisted Living Technology Usage: Scenario-Based Survey Study - Julia Offermann-van Heek, Martina Ziefle; *JMIR Rehabil Assist Technol.* 2018 Jul-Dec; 5(2): e10424. Published online 2018 Sep 24. doi: 10.2196/10424
10. Introducing ambient assisted living technology at the home of the elderly: challenges and lessons learned - D Muñoz, FJ Gutierrez, SF Ochoa, Dec 2015, DOI: 10.1007/978-3-319-26410-3\_12
11. Stefanov, D.H.; Bien, Z.; Bang, W.-C. The smart house for older persons and persons with physical disabilities: Structure, technology arrangements, and perspectives. *Neural Syst. Rehabil. Eng. IEEE Trans.* 2004, 12, 228–250
12. 5G Infrastructure Public Private Partnership (5G PPP): View on 5G Architecture (Version 2.0), 5G PPP Architecture Working Group - 2017-07-18
13. ETSI: GS NFV 002 Network Functions Virtualization (NFV); Architectural Framework, v.1.1.1, 10-2013
14. 163. Bruno Dzugovic, Bernardo Santos, Josef Noll, Van Thuan Do, Boning Feng and Thanh Van Do: Enabling Smart Home with 5G Network Slicing, Proceedings of the 2019 IEEE 4th International Conference on Computer and Communication Systems ICCCS 2019, ISBN 978-1-7281-1321-0, IEEE Catalog Number CFP19D48-USB, pp 543-548, Conf. Chair Yang Xiao, Singapore, 23-25 February 2019
15. 3rd Generation Partnership Project (3GPP): Technical Specification TS 23.501 V1.3.0 (2017-09) Technical Specification Group Services and System Aspects; System Architecture for the 5G System; Stage 2 (Release 15) 09-2017
16. 5G Infrastructure Public Private Partnership (5G PPP): View on 5G Architecture (Version 2.0), 5G PPP Architecture Working Group - 2017-07-18
17. Park, J.-H.; Jang, D.-G.; Park, J.; Youm, S.-K. Wearable Sensing of In-Ear Pressure for Heart Rate Monitoring with a Piezoelectric Sensor. *Sensors* 2015, 15, 23402–23417
18. Zao, J.K.; Wang, M.-Y.; Tsai, P.; Liu, J.W.S. Smartphone based medicine in-take scheduler, reminder and monitor. In Proceedings of the 2010 12th IEEE International Conference on e-Health Networking Applications and Services (Healthcom), Lyon, France, 1–3 July 2010; pp. 162–168
19. Popescu, M.; Li, Y.; Skubic, M.; Rantz, M. An acoustic fall detector system that uses sound height information to reduce the false alarm rate. In Proceedings of the 30th Annual



- International Conference of the IEEE Engineering in Medicine and Biology Society (EMBS 2008), Vancouver, BC, Canada, 21–24 August 2008; pp. 4628–4631
20. Bottazzi, D.; Corradi, A.; Montanari, R. Context-aware middleware solutions for anytime and anywhere emergency assistance to elderly people. *IEEE Commun. Mag.* 2006, 44, 82–90
  21. Lawton, M.P., & Brody, E.M. (1969). Assessment of older people: Self-maintaining and instrumental activities of daily living. *The Gerontologist*, 9(3), 179-186.
  22. [https://www.rand.org/health/surveys\\_tools/mos/36-item-short-form.html](https://www.rand.org/health/surveys_tools/mos/36-item-short-form.html)
  23. [https://ec.europa.eu/economy\\_finance/graphs/2015-05-12\\_ageing\\_reporten.htm](https://ec.europa.eu/economy_finance/graphs/2015-05-12_ageing_reporten.htm)
  24. KS – Kommunes Sentralforbund (Norwegian Association of Local and Regional Authorities)
  25. <https://www.innovasjon Norge.no/no/tjenester/innovasjon-og-utvikling/finansiering-for-innovasjon-og-utvikling/innovasjonskontrakter/innovation-contracts/>
  26. <https://www.innovasjon Norge.no/no/tjenester/oppstart-av-bedrift/oppstartfinansiering/kommersialiseringstilskudd/>
  27. OpenAirInterface Software Alliance (OSA): a non-profit consortium fostering a community of industrial as well as research contributors for open source software and hardware development for the core network (EPC), access network and user equipment (EUTRAN) of 3GPP cellular networks. <https://www.openairinterface.org/>
  28. B. Santos, V. T. Do, B. Feng, and T. van Do, “Identity Federation for Cellular Internet of Things,” in *Proceedings of the 2018 7th International Conference on Software and Computer Applications - ICSCA 2018*, 2018, pp. 223–228.
  29. B. Santos, V. T. Do, B. Feng, and T. van Do, “Towards a Standardized Identity Federation for Internet of Things in 5G Networks,” in *2018 IEEE SmartWorld 2018 Proceedings*, pp. 2082–2088.
  30. Gluu Server- <https://www.gluu.org/> (Last Accessed – May 2019)
  31. 5G-VINNI: 5G Verticals INNOVation Infrastructure, an European H2020-ICT-2017 research project which aims at accelerating the uptake of 5G in Europe by providing an end-to-end (E2E) facility that validates the performance of new 5G technologies by operating trials of advanced vertical sector services