

Examining the regulating impact of thermal mass on overheating, and the role of night ventilation, within different climates and future scenarios across China

Hao Sun^{a,*}, John Kaiser Calautit^a, Carlos Jimenez-Bescos^b

^a Department of Architecture and Built Environment, University of Nottingham, UK

^b Department of Civil Engineering and Energy Technology, Oslo Metropolitan University, Oslo, Norway

ARTICLE INFO

Keywords:

Overheating
Thermal mass
Night ventilation
Dynamic building simulations
Climate regions
Future weather

ABSTRACT

An ever-increasing challenge of global warming and climate change is the issue of overheating in buildings. Several studies have developed numerous passive strategies to lessen the effects of overheating and reduce cooling energy consumption. For instance, thermal mass stores the thermal energy, which locks the heat away and prevents overheating. However, this must be discharged daily to ensure it can be used to store heat again. This discharging of heat can be achieved by night ventilation. The purpose of this research is to investigate the use of thermal mass and night ventilation in different climate conditions in China to minimise overheating in buildings under future climate conditions in 2050s and 2080s with four different greenhouse gas (GHG) emission scenarios. An office space model was employed to run full-year dynamic building simulations using Energyplus to simulate each thermal mass configuration in five cities (Guangzhou, Kunming, Shanghai, Beijing and Harbin) across China with varying climatic conditions. The study enabled the thermal mass configuration to be optimised for each specific climate and with the integrated night ventilation. The results highlighted night ventilation's vital role in decreasing overheating. The impact of night ventilation was found to reduce overheating hours by up to 60%. The method and results presented in this research can provide means for formulating strategies to combat overheating and to be incorporated into the regulations of buildings in China.

1. Introduction

The increased frequency and severity of extreme weather events have made global warming and climate change top priority concerns for many societies (Yau and Hasbi, 2013). Climate change has been observed through a gradual increase in mean temperatures, rising sea levels, and ice melting at the poles and elsewhere (Yau and Hasbi, 2013). The effect of climate change has increased summer mean temperatures across the Northern Hemisphere. In China, the country now experiences much warmer summers, thereby impacting the operation of buildings. The warmer summers and colder winters are causing an increased building energy demand, leading to higher emissions. Studies have shown that more than 40% of the world's energy consumption is directly related to construction, and this is growing due to hotter summers and colder winters (Cao et al., 2016).

One of the most detrimental consequences of climate change on buildings is overheating. Studies have indicated the presence of

increased overheating within temperate climate regions, as well as in other places (Hamdy et al., 2017). The increased energy consumption from buildings leads to a significant load on the overall energy and transmission network. Furthermore, overheating negatively impacts human health and damages sleep quality (Hamdy et al., 2017). Moreover, overheating can also result from certain energy efficiency policies for the building sector (Hatvani-Kovacs, 2019). Researchers are currently exploring effective methods to alleviate its effects without increasing energy consumption. These methods include passive cooling strategies and technologies such as thermal mass.

Passive cooling via thermal mass relies on the building fabric to absorb and store heat, reducing the amount of energy used by a building (Jimenez-Bescos, 2017). During the summer, the transfer of heat from the outdoor environment into the inside is slowed down by the thermal inertia of thick external walls (Shaviv et al., 2001). Thus, a high thermal mass building essentially behaves like a battery, where it captures and retains heat from the outside by a gradual transfer method. Hence, these

* Corresponding author.

E-mail address: Hao.Sun@nottingham.ac.uk (H. Sun).

<https://doi.org/10.1016/j.clet.2022.100534>

Received 31 January 2022; Received in revised form 15 June 2022; Accepted 5 July 2022

Available online 14 July 2022

2666-7908/© 2022 The Authors. Published by Elsevier Ltd. This is an open access article under the CC BY license (<http://creativecommons.org/licenses/by/4.0/>).

buildings act as a storage for heat, which works well in the winter as they can store and slowly release the heat. In essence, thermal inertia can counteract overheating and reduce the energy demands of buildings.

Night ventilation can take away some of the heat stored in the heavy walls during the day (Shaviv et al., 2001). Yet, inefficient ventilation can enhance overheating, and a high differential between the outdoor environment and indoor temperature can decrease the efficiency of night ventilation (Lomas and Porritt, 2017). (Shaviv et al., 2001) carried out a study in Florida where they looked at the impact of heavyweight thermal mass and night ventilation on overheating reduction. They observed that such a passive cooling strategy is not suitable for regions with a very hot climate. The effectiveness of such a passive strategy may be affected in different regions and climatic conditions in the future.

In this study, five Chinese cities, namely Harbin, Beijing, Shanghai, Guangzhou, and Kunming, were chosen to test the effects of night ventilation and thermal mass on overheating in varying climatic conditions taking into account the influence of climate change in the future.

2. Literature review

A growing number of studies have confirmed the existence of a link between climate change and building overheating. Overheating conditions have been observed repeatedly in many northern hemisphere countries (Lomas and Porritt, 2017). Overheating is becoming a growing concern for the building sector. (Peacock et al., 2010) studied the phenomena of overheating within UK residential buildings. They used dynamic simulation to predict the future building overheating in the UK and found that the risk of lightweight buildings and dwellings located in the south of England are higher than in other models. In their main scenario, the average indoor temperature of the tested bedroom is over 28 °C for almost 12% of the year. Several researchers concluded that the problem of building overheating frequently occurs in the south of the UK. While (Morgan et al., 2017) found that low-energy buildings are also susceptible to overheating in Scotland and that more than 54% of the tested newbuild homes undergo overheating for more than 6 months every calendar year.

In the Netherlands (Hamdy et al., 2017), used the building performance simulation program IDA-ICE to explore Dutch dwellings and their capacity to respond to overheating. They selected thousands of Dutch houses built between 1964 and 2013, and their results showed that most Dutch buildings could deal with the negative effects of climate change. However, poorly ventilated houses are prone to overheating.

(Guo et al., 2020) studied overheating within the colder climate areas of China and honed in on the effects of two specific construction materials, including reinforced concrete (RC) and cross-laminated timber (CLT), on overheating. The research involved six cities that are present in cold climates. They concluded that buildings made of CLT experience longer overheating hours compared to buildings made of RC. Their results suggest that local energy efficiency design standards need to be adjusted to reduce overheating periods.

In New Zealand, there are no existing standards about minimum airtightness. To reduce heating energy consumption in winter, people prefer to increase insulation levels, which raises the risk of the building overheating in summer (Birchmore et al., 2017). monitored the indoor temperature and humidity of three unoccupied houses and showed that the indoor temperature went to 32 °C in autumn, while the roof temperature was found to reach a maximum of 51 °C. Thus, they proposed interventions to reduce pronounced overheating risk, such as increasing the ventilation rate on the roof.

There is no international standardised criterion for overheating. Overheating is generally associated with thermal discomfort, but countries have different standards for thermal comfort. In China, most standards for evaluating thermal comfort have been developed for residential buildings. While there are few standards for thermal comfort and overheating in office buildings and public areas.

The work carried out by the Chartered Institution of Building

Services Engineers (CIBSE) is a prime example of the development of standards for overheating. The CIBSE TM36 scenario takes into account the impact of climate change and indoor environment while setting the specific criteria for overheating as being higher than 28 °C for more than 1% of the residence time, or the temperature being higher than 25 °C for more than 1% of the occupied hours (CIBSE, 2005). CIBSE TM36 has subsequently been replaced by CIBSE TM52 and CIBSE TM59. CIBSE TM52 specifies that the operating temperature of rooms with primarily mechanical ventilation in summer should not exceed 26 °C (CIBSE, 2013). CIBSE TM59 mandates that the operating temperature in bedrooms should not exceed 26 °C between the hours of 10pm and 7am, and the peak temperature should never be higher than 1% of the annual time in naturally ventilated dwellings (CIBSE, 2017). CIBSE Guide A specifies the peak temperatures and overheating criteria for the design of buildings. The peak temperature is 28 °C for offices, schools, and living rooms, and it is 26 °C for bedrooms (CIBSE, 2006). The ANSI/ASHRAE Standard 55-2017 was formed by the American Society of Heating, Refrigerating, and Air Conditioning Engineers (ASHRAE) in the United States. It states that the acceptable operating temperature range for naturally conditioned spaces is based on field test data from office buildings (ASHRAE, 2017). In China, the number of cooling degree days is based on 26 °C and heating degree days is based on an 18 °C threshold (GB50176-2016). Overall, most of the overheating standards are based on thermal comfort indicators. Two accepted thermal comfort models are Fanger's predicted mean vote (PMV) and predicted percentage dissatisfaction (PPD) models.

When considering the energy efficiency measures, many studies tend to focus on the thermal resistance ('U- Value') but ignore the role of thermal mass. This is a major mistake since thermal mass is what signifies the ability of a building to absorb and store heat energy which has a major impact on indoor temperatures, as well as the comfort of residents (Reilly and Kinnane, 2017). Reilly and Kinnane investigated high and low thermal mass wall configurations in warmer and colder environments. High and low thermal mass wall were tested in Madrid (Spain) in summer and Belfast (Northern Ireland) in winter to compare the temperature response to each wall. Their results show that buildings with high thermal mass can be useful in warm climates, however, they can increase building energy consumption in cold climates (Reilly and Kinnane, 2017).

Burch et al. studied the effects of thermal mass on the heating and cooling load of six single family rooms with different wall types in Maryland (USA). The outcome of their study shows that thermal mass can reduce overheating during warm periods of the year. Previous research also explored the effect of thermal mass in hot climate regions (Burch et al., 1986). Stevens et al. (2016) investigated the influence of thermal mass on energy usage in buildings located in colder climates, using the IDA ICE to build one hypothetical building in Alaska and compare the annual heat load and thermal comfort based on different thermal mass conditions. They found that in such a cold climate, increasing thermal mass can decrease the risk of overheating in summer but cannot reduce the annual heat demand of the building significantly.

(Shaviv et al., 2001) investigated the effect of thermal mass and night ventilation on maximum interior air temperature in four specific districts of Israel throughout the summer. They set four-night ventilation scenarios with different air change rates (0, 5, 20, and 30) and four varying thermal mass conditions (light, medium-light, semi-high, and high) to find the reduction in the maximum indoor temperature compared with maximum outdoor temperature for predicting the thermal performance of the building. The results showed that in the heavy building, there was a decrease in indoor temperature between 3 °C and 6 °C, and the thermal performance was influenced by the thermal mass, night ventilation rate, and the temperature swing of the day and night.

(Amos-Abanyie et al., 2013) studied the impact of thermal mass, night ventilation, and window size on peak indoor air temperature. They evaluated a building in Ghana using Energyplus, focusing on the effects of these three variables, they found that by changing the density of

different materials, concrete showed the highest effect in reducing the peak indoor air temperature and maintained a drop of 3 °C and the overheated hour was reduced up to 30% based on 10 ach per hour, however, there was no significant change when the air change rate was adjusted to 20 ach and 30 ach.

(Jimenez-Bescos, 2017) analysed the impact of night ventilation on thermal mass to decrease overheating. Three climate and emission scenarios for London, Islington in the 2030s, 2050s, and 2080s were selected to compare to simulated results from 1970s. Different night ventilation rates were evaluated to understand the impact on thermal mass performance. It was observed that overheating can only be significantly reduced when the night ventilation rate is at least 8 ach. However, a ventilation rate of less than 10 ach only causes a minimal reduction in overheating for high emission situations, and it is necessary to find other passive cooling strategies (Jimenez-Bescos, 2017).

Many studies in this discipline primarily look at weather forecasting, the influence of climate change on building overheating and the building life cycle carbon emission (Li, 2021). (Jentsch et al., 2008, 2013) have created the CCWorldWeatherGen software, which uses Microsoft Excel, and enables users to formulate future weather data for the following periods: 2020s, 2050s, and 2080s, in the form of EPW files. These files provide four different scenarios based on Intergovernmental Panel on Climate Change (IPCC) assigned GHG emission scenarios: A1FI (High); A2 (Medium-high); B1 (Medium-low); and B2 (Low). (Alhindawi and Jimenez-Bescos, 2020) use future weather predictions to decipher the role of climate change in the analysis stage of constructing buildings. They used Energyplus with the future weather data in the high and medium-high emission scenarios of greenhouse gas (GHG) emissions in the 2050s and 2080s to understand the effect of thermal comfort ranges, passive zone potential, as well as heating/cooling periods and used them to compare with weather data ranging from 2003 to 2017. The results showed that the high GHG emissions scenario led to a major impact on daily cooling hours and monthly coverage.

Studies have shown that thermal mass and night ventilation can be used together to decrease energy consumption across different climates. A building's lifespan is estimated to range from around 60 to over 100 years, thus, the impact of many overheating scenarios within buildings must be studied to enhance their effectiveness in varying climates (Yau and Hasbi, 2013). Prediction models and studies on building overheating are still scarce, as most researchers seem to be primarily concerned with predicting the adaptability of buildings to different future weather conditions. Previous researchers mainly focused on the influence of thermal mass and night ventilation on overheating, and few of them paid attention to the impact of future weather conditions on the overheating issues. Furthermore, the literature tends to focus on specific climatic regions such as hot humid and cold climates, while few studies investigate overheating in multiple climate zones and predict future overheating.

3. Method

This section highlights the framework of the study and the details of simulation models, as well as representative cities evaluated. Moreover, weather forecasting methods and the associated parametric analysis are discussed.

3.1. Evaluation workflow

This research follows the methodological steps detailed below to understand the impact of thermal mass and night ventilation on overheating in varying climate zones across China. Firstly, the baseline office model was created with Sketchup and the Openstudio Plugin in order to prepare for the set up of the energy model in Energyplus.

Secondly, the three models with different thermal mass and night ventilation conditions were set. Thirdly, the Weather Morph was used to create the EPW weather files based on future scenarios. In this study, five

Chinese cities and four different scenarios were evaluated. Energyplus was used to simulate building energy consumption, as well as the indoor operative temperature. Lastly, each model was analysed in terms of overheating hours during working periods. Fig. 1 highlights the simulation and evaluation workflow. The simulation is formed up of three aspects:

- 1) The validation of the baseline building energy model;
- 2) Using the Weather Morph to generate future weather files;
- 3) Using the Energyplus tool to predict the hourly indoor operational temperature during working hours.

3.2. The baseline model (Case600FF and Case900FF)

Test office spaces were modeled based on the Case 600FF and Case900FF, which are lightweight and heavyweight thermal mass models respectively, without mechanical heating or cooling system referring to (Robert and Michael, 2004). As shown in Fig. 2., both Case600FF and Case900FF have the following dimensions for 8 m × 6 m × 2.7 m. The settings specified in the Energyplus dynamic computational simulation were based on the Energyplus testing with ANSI/ASHRAE Standard 140–2001(BESTEST) (Robert and Michael, 2004) and are shown in Table 1 and Table 2. Table 3 shows the setting of two unshaded windows on the south surface. Infiltration was set to 0.5 air change/hour. The internal load was set to 200 W continuous, 100% sensible, 40% convective, and 60% radiative. The soil temperature was 10 degC continuous.

3.3. Models with varying thermal mass conditions and with or without the night ventilation

Table 4 indicates the testing models alongside the varying conditions of the thermal mass and night ventilation (Robert and Michael, 2004).

The addition of a specific night ventilation schedule was set for the Case 650FF and Case950FF, all the other settings are similar to Case600FF and Case900FF, apart from the addition of a specific night ventilation schedule, the vent fan is working from 6pm to 7am, and it was turned off from 7 a.m. to 6 p.m., in addition to the specified infiltration rate, for the 129.6 m³simulating space, the capacity of the vent fan is 1703.16 standard m³/h.

3.4. Model validation

In Table 5, the validation results for four different cases are listed, and the results are compared with (Robert and Michael, 2004). For such a comparison, three variables were selected, i.e., the maximum annual hourly zone temperature, the minimum annual hourly zone temperature, and the average annual hourly zone temperature. As indicated from the comparative results, the errors were small, which demonstrated that the model could be reliable.

3.5. Simulation case study cities

According to the Standard on Division of Climate Zones for Buildings, these cities are all present in varying parts of China which account for the five climates of China (severe cold, cold, hot summer, cold winter, HSCW), hot summer and warm winter (HSWW), and mild (GB50178-93, 1993). In the present study, five representative cities from different climates in China were selected for the simulation. To be specific, Harbin, Beijing, Shanghai, Kunming and Guangzhou were the locations selected, five cities located in the different climate zones in China (shown in Fig. 3), to analyse the effect of overheating situations under different climates. The characteristics of these location's altitude and weather data locations are listed in Table 6 and Table 7.

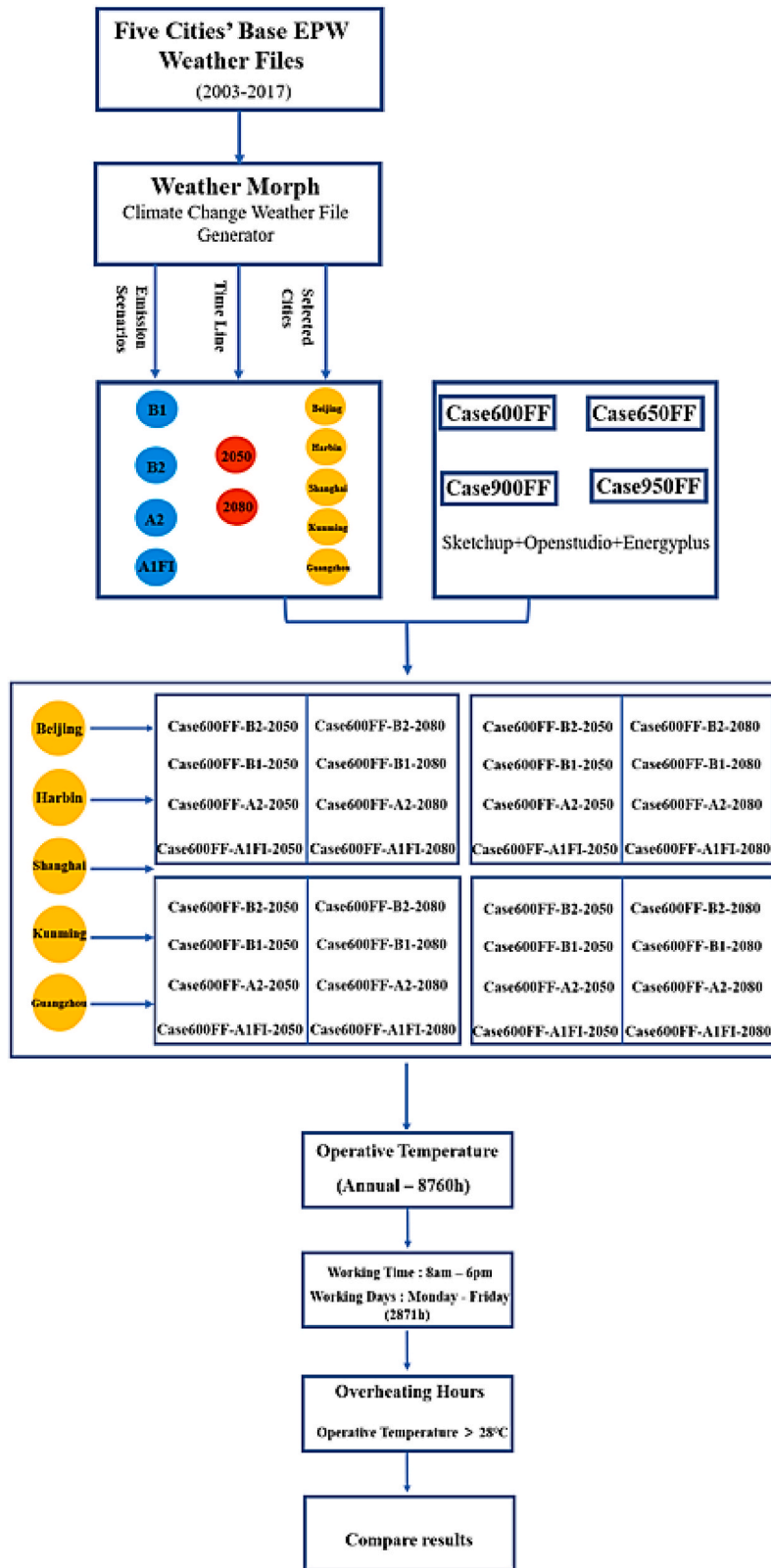

Fig. 1. Modelling and evaluation workflow employed in this study.

3.6. Future weather simulation method

The basic weather files of all 5 cities were merged onto Weather Morph, a Climate Change Weather Data Generator platform with HadCM3 scenarios, since this enables future weather data to be

formulated (Jentsch et al., 2013). This tool can create future weather data for four emission scenarios in over 2100 places throughout the world over three time periods. (i.e., the 2020s, 2050s and 2080s). All these four scenarios were classified into four levels in relation to the IPCC (Intergovernmental Panel on Climate Change) emissions. Hence,

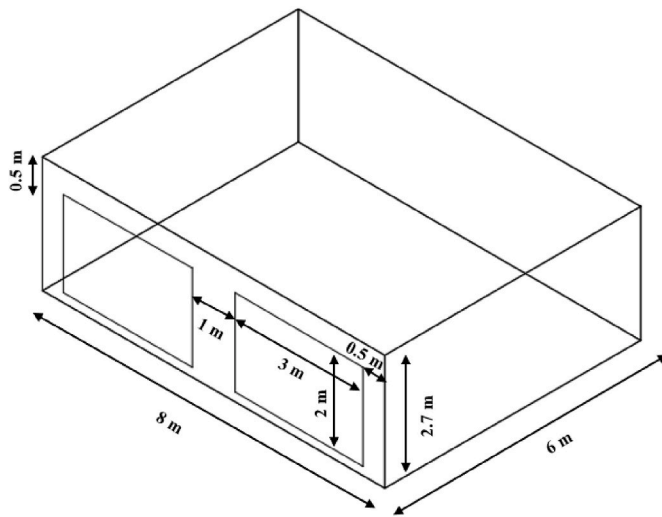

Fig. 2. Baseline model Case600FF for simulation.

this ensured simulation of future GHG emissions, i.e., Scenarios: A1FI (High); A2 (Medium-high); B1 (Medium-low); and B2 (Low). (Alhindawi and Jimenez-Bescos, 2020; Jiang et al., 2019). All the bare basic weather files were formed (DOE, 2021), and the weather simulation locations are listed in Table 6. 80 models were simulated in Energyplus (Fig. 4.).

Table 1
Material information for Case600FF (Robert and Michael, 2004).

Construction	Case600FF					
	Element	K (W/m-K)	Thickness (m)	U (W/m ² -K)	Density (kg/m ³)	CP (J/kg-K)
Wall	Internal surface coefficient			8.290		
	Plasterboard	0.160	0.012	13.333	950	840
	Fiberglass quilt	0.040	0.066	0.606	12	840
	Wood siding	0.140	0.009	15.556	530	900
	External surface coefficient			29.300		
	Overall			0.514		
Roof	Internal surface coefficient			8.290		
	Plasterboard	0.160	0.012	16.000	950	840
	Fiberglass quilt	0.040	0.112	0.358	12	840
	Roof deck	0.140	0.019	7.368	530	900
	External surface coefficient			29.300		
	Overall			0.318		
Floor	Internal surface coefficient			8.290		
	Timber flooring	0.140	0.025	5.600	650	1200
	Insulation	0.040	1.003	0.040		
	Overall			0.039		

Table 2
Material information for Case900FF (Robert and Michael, 2004).

Construction	Case900FF					
	Element	K (W/m-K)	Thickness (m)	U (W/m ² -K)	Density (kg/m ³)	CP (J/kg-K)
Wall	Internal surface coefficient			8.290		
	Concrete block	0.510	0.100	5.100	1400	1000
	Foam insulation	0.040	0.0615	0.651	10	1400
	Wood siding	0.140	0.009	15.556	530	900
	External surface coefficient			29.300		
	Overall			0.512		
Roof	Internal surface coefficient			8.290		
	Plasterboard	0.160	0.012	16.000	950	840
	Fiberglass quilt	0.040	0.112	0.358	12	840
	Roof deck	0.140	0.019	7.368	530	900
	External surface coefficient			29.300		
	Overall			0.318		
Floor	Internal surface coefficient			8.290		
	Concrete slab	1.130	0.080	14.125	1400	1000
	Insulation	0.040	1.007	0.040		
	Overall			0.039		

3.7. Parametric analysis process

The variable of the simulation was the hourly indoor operative temperature. For the full year simulation, the models collected the indoor air temperature for each hour. These models were used to predict potential office overheating; since the simulation was conducted in offices, we defined a concept of “workday-working hours” in this study, based on regular working hours, five days a week, from Monday to Friday, and a 11-h from 7:00 a.m. to 6:00 p.m. for each day consist of the

Table 3
Two windows’ settings (Robert and Michael, 2004).

Window Properties	
Number of panes	2
Pane thickness	3.175 mm
Air-gap thickness	13 mm
Thermal Conductivity of glass	1.06 W/mK
Density of glass	2500 kg/m ³
Specific heat of glass	50 J/kgK

Table 4
Conditions of the thermal mass and the night ventilation for baseline models.

Model Name	Thermal mass Condition	Night Ventilation (NV) Condition
Case600FF	Light-weight	Without NV
Case650FF	Light-weight	With NV
Case900FF	Heavy-weight	Without NV
Case950FF	Heavy-weight	With NV

Table 5
Validation results for different cases.

BESTEST Case	600FF	900FF	650FF	950FF
Maximum Annual Hourly Zone Temperature (C)				
BESTEST Minimum	64.9	41.8	63.2	35.5
BESTEST Maximum	75.1	46.4	73.5	38.5
BESTEST Average	67.7	43.7	66.1	36.6
Present Study	66.2	44.9	63.7	37.8
Difference, %	-2.2%	2.7%	1.8%	3.3%
Minimum Annual Hourly Zone Temperature (C)				
BESTEST Minimum	-18.8	-6.4	-23.0	-20.3
BESTEST Maximum	-15.6	-1.6	-21.0	-17.8
BESTEST Average	-17.6	-3.7	-22.4	-19.3
Present Study	-17.6	-2.9	-23.1	-20.0
Difference, %	0%	-21%	3.3%	-1.5%
Average Annual Hourly Zone Temperature (C)				
BESTEST Minimum	24.2	24.5	18.0	14.0
BESTEST Maximum	27.4	27.5	20.8	15.3
BESTEST Average	25.3	25.5	18.9	14.5
Present Study	26.1	26.3	18.9	14.6
Difference, %	3.1%	3.1%	0%	0.69%

“workday-working hours”. Assuming that the simulated year consists of 365 days and the total number of hours is 8760h (365 × 24), the “workday-working hours” is using the filtering tool in EXCEL to filter out 2761 h, and the following study is to simulate the overheating situation for this 2761 working hours.

Several criteria should be met to evaluate the overheating. CIBSE Guide A defines the peak temperature and overheating standards for offices, with a peak temperature of 28 °C (CIBSE, 2006). (Guo et al., 2020) evaluated the overheating phenomenon in summer in cold and severe cold regions in China. According to their study, the overheating limitation was set to 26 °C with air conditioning by complying with the (GB50176-2016, 2016). In this study, simulated models without mechanical heating or cooling system, the interior peak operating temperature was set to 28°C.

4. Results

Overall, 160 simulations were conducted by employing Energyplus in free floating mode, whereas no cooling was set to prevent overheating. The building was prevented from overheating during the presence of thermal mass and night ventilation. The model was hypothesised as an office space, in which the 2871 h for the “workday-working hours” in a year were filtered out. In such a period, the number of hours overheated above 28 °C were counted, and the percentage of the overheating hours in the office during the working hours was also calculated. Furthermore, the following figures highlight the proportion

Table 6
Selected cities’ location and climate condition (GB50178-93, 1993).

Cities	Location (North Latitude-East Longitude)	Altitude (m)	Climate Conditions
Harbin	45° 45'-126° 46'	142.3	Severe Cold
Beijing	39° 48'-116° 28'	31.5	Cold
Shanghai	31° 10'-121° 26'	4.5	Hot Summer Cold Winter
Kunming	25° 01'-120° 41'	1891.4	Temperate
Guangzhou	23° 08'-113° 19'	6.6	Hot Summer Warm Winter

Table 7
Weather data and simulation locations.

Cities	Weather Data and Simulation Locations
Harbin	Taiping International Airport
Beijing	Beijing Capital International Airport
Shanghai	Pudong International Airport
Kunming	Wujiaba International Airport
Guangzhou	Baiyun International Airport

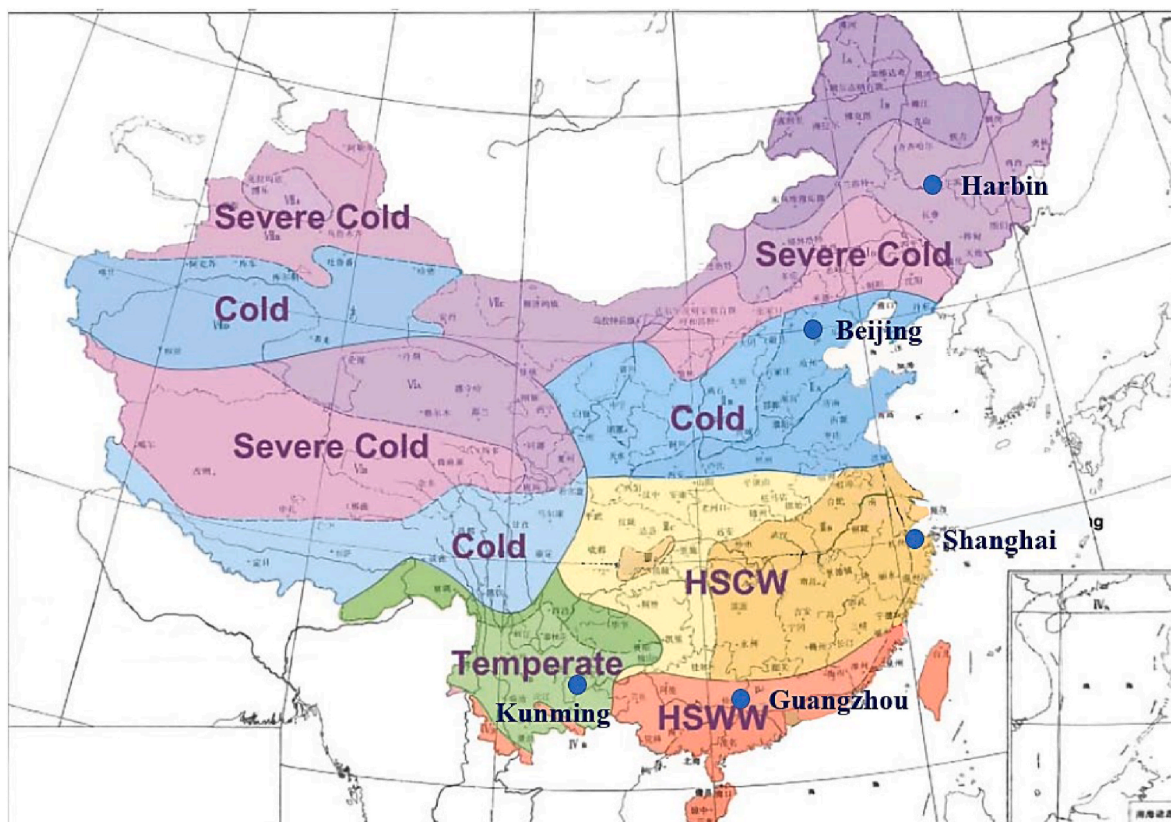

Fig. 3. Five different climates in China and five selected cities. (Data from (GB50178-93, 1993). Modified by the author).

Cities		Models with future weather data				
Harbin	2050s	B1	Case600FF	2080s	B1	Case600FF
			Case650FF			Case650FF
			Case900FF			Case900FF
			Case950FF			Case950FF
Beijing	2050s	B2	Case600FF	2080s	B2	Case600FF
			Case650FF			Case650FF
			Case900FF			Case900FF
			Case950FF			Case950FF
Shanghai	2050s	A2	Case600FF	2080s	A2	Case600FF
			Case650FF			Case650FF
			Case900FF			Case900FF
			Case950FF			Case950FF
Kunming	2050s	A1FI	Case600FF	2080s	A1FI	Case600FF
			Case650FF			Case650FF
			Case900FF			Case900FF
			Case950FF			Case950FF
Guangzhou	2080s	A1FI	Case600FF	2080s	A1FI	Case600FF
			Case650FF			Case650FF
			Case900FF			Case900FF
			Case950FF			Case950FF

Fig. 4. Models with future weather data in five cities.

of overheating hours compared to the total working hours. According to these figures, the averages of the percentage changes in 2050s and 2080s are represented by different colours, with blue representing a reduction in overheating percentage and red representing an increase in overheating.

4.1. Comparison of building model with different thermal mass conditions

Five Chinese cities located in five climate zones were selected to understand the impact of varying thermal masses on the issue of building overheating. They were simulated based on the future weather

files (the 2050s and 2080s), and four GHG emission scenarios were considered. Fig. 5 highlights the overheating hours and the percentage of these hours during the total working period within the five cities. This was based on the Case600FF and Case900FF, both of which had distinct thermal masse conditions. In Fig. 6, the proportion change is showcased.

From all the lightweight thermal cases (Case600FF), in the similar GHG emission scenarios, the Case600FF from Harbin in the serve cold climate to Guangzhou in the HSWW climate achieved more overheating when the climate became warmer, except for Kunming located in the temperate climate. The low number of overheating hours in Kunming under the Case600FF could be explained as impacted by the

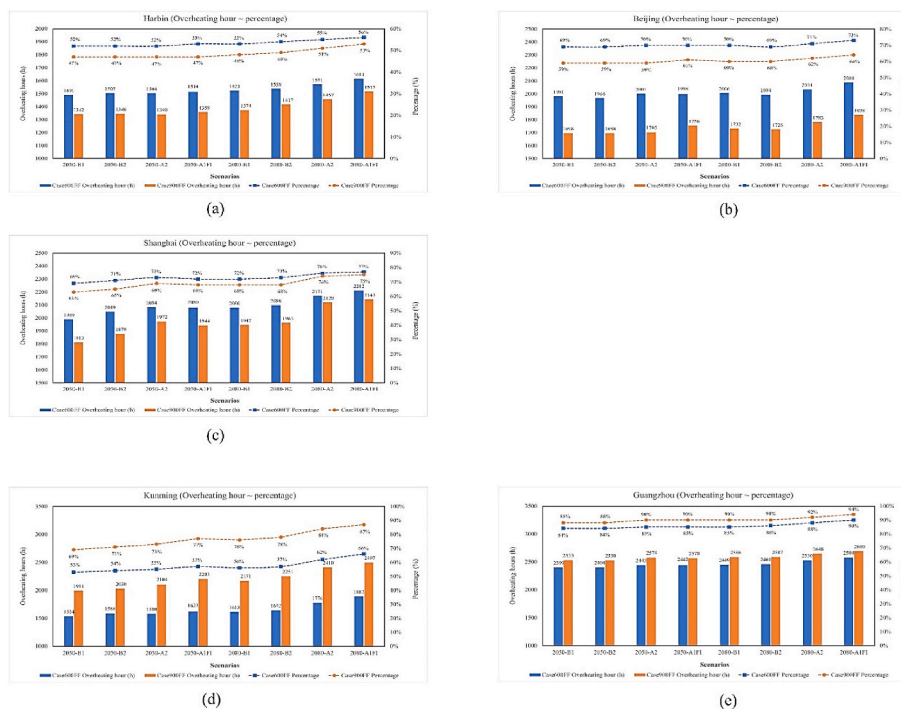

Fig. 5. Comparative findings of Case600FF and Case900FF in five selected cities in different scenarios in the 2050s and 2080s based on the number of overheating hours and the percentage of overheating hours in 2871 total working hours.

insignificant temperature differences across the year and the high humidity in this climate zone compared with other climates.

For all the heavyweight thermal cases (Case900FF), from the severe cold climate to the HSWW climate, the number of overheating hours increased. After the results of the number of overheating hours in 2050s and 2080s in different scenarios of the respective city were counted, the average of the overheating hours for 8 different scenarios was determined for each city. Moreover, the average overheating hours for Case900FF from Harbin to Guangzhou reached 1394, 1741, 1973, 2207 and 2590, respectively.

The cities of Harbin, Beijing and Shanghai are in the severe cold climate, the cold climate and the HSCW climate, respectively. The use of heavyweight thermal mass can reduce overheating to varying degrees. Overheating hours were reduced in the 2050s and 2080s by employing materials with a higher thermal value. In Fig. 6., in the 2050s, the average overheating hours for Harbin decreased by 5.25%, and for Shanghai, it decreased by 5%. Moreover, in Beijing, which is present in the cold climate area, the drop was on average 10%. However, in the temperate and HSWW climate, the opposite effect was achieved by using the heavyweight thermal mass to relieve the overheating. As compared with Case600FF in Kunming and Guangzhou in the 2050s, the overheating hours increased by 17.5% and 4.5%, respectively, the heavyweight thermal mass extended the duration of the overheating in temperate climates and affected the comfort. In 2080s, the increase or decrease in the percentage of the overheating in each city was similar to that in 2050, whereas the effectiveness of the thermal mass to reduce the overheating was suggested to decrease over time. According to such a result, the overheating can be reduced by using different thermal masses, and the selection of the appropriate thermal mass is determined by the climatic conditions of the different cities.

As indicated through a comparison of multiple GHG emission scenarios in the same city in the 2050s and 2080s, higher levels of emissions

led to an increase in overheating hours. Thus, this shows that global warming is a cause of building overheating.

4.2. The influence of night ventilation with the lightweight thermal mass on overheating

The ability of night ventilation to reduce building overheating was studied with the Case650FF, which is the same as Case600FF, apart from the addition of the extra night ventilation simulation from 6 p.m. to 7 a.m. Fig. 7 shows the overheating hours and percentage of these hours during total working time within the five cities, under the lightweight thermal mass.

The results show that night ventilation can decrease building overheating in cities from different climatic zones, whereas the effectiveness in reducing the overheating hours was different. In the 2050s, in Kunming, according to the temperate climate, the usage of the night ventilation was most productive in reducing overheating, and a percentage reduction of 4.5% was achieved on average. In Shanghai, the overheating decreased by 2.5% on average, which decreased between 1% and 2% in the other three cities. In 2080s, the reduction in the percentage of the overheating compared with that in 2050s was lower for all cities except for Harbin, which demonstrated a consistent result (Fig. 8.). Harbin, located in the severe cold climate, and Guangzhou in the HSWW climate zone achieved almost the same effect of using the night ventilation to reduce the overheating under the lightweight thermal mass. As indicated from the result, the impact of night ventilation on reducing overheating is not directly correlated to climate differences.

The Case600FF and Case650FF differences were examined in various situations under anticipated future climatic conditions. It was found that overheating hours higher than 28 °C were far longer in the case of high emissions than those with lower emissions. Hence, this shows that high emissions enhance the effects of global warming. Thus, this results in

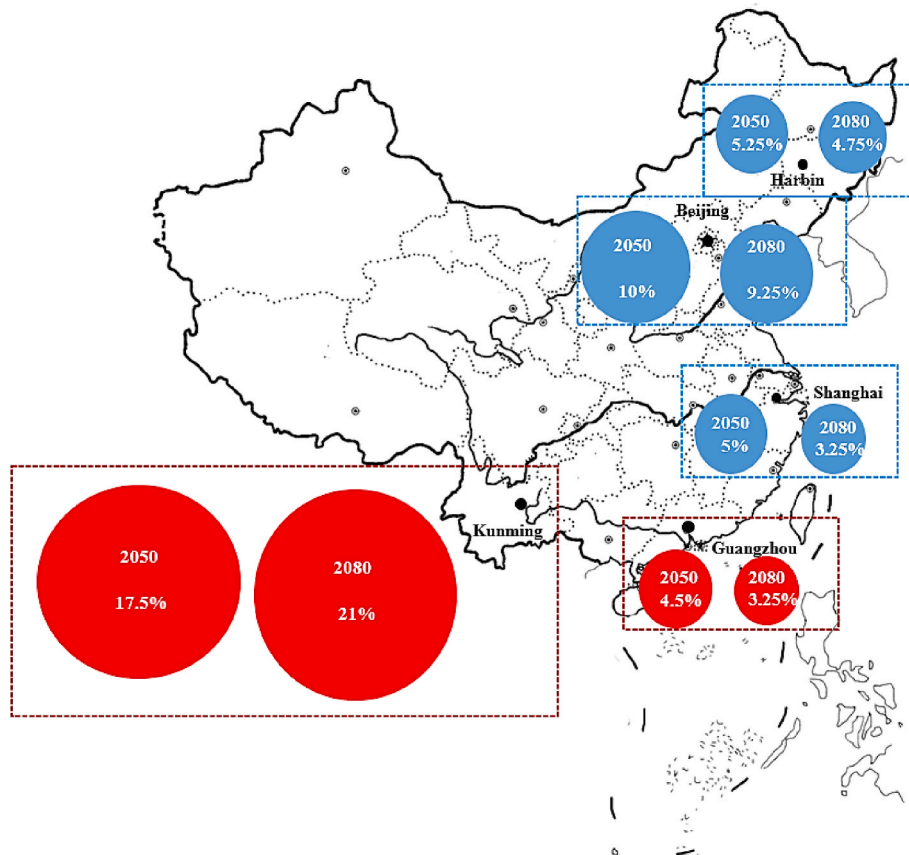

Fig. 6. The change proportion of the overheating - comparative results based on the Case600FF and the Case900FF for five selected cities in the 2050s and 2080s.

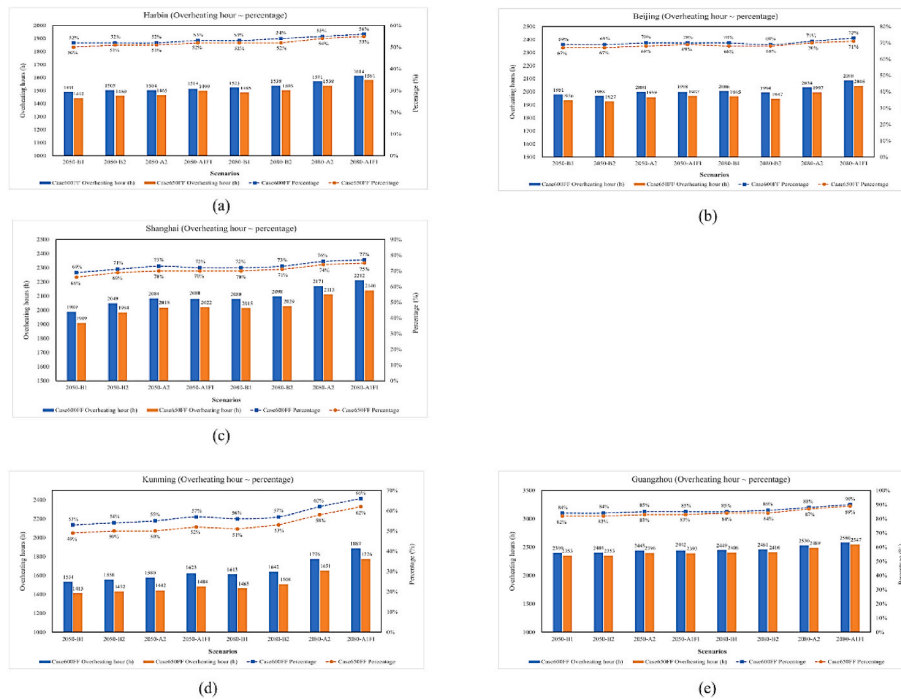

Fig. 7. Comparative findings of Case600FF and Case650FF in five selected cities in different scenarios in the 2050s and 2080s based on the number of overheating hours and the percentage of overheating hours in 2871 total working hours.

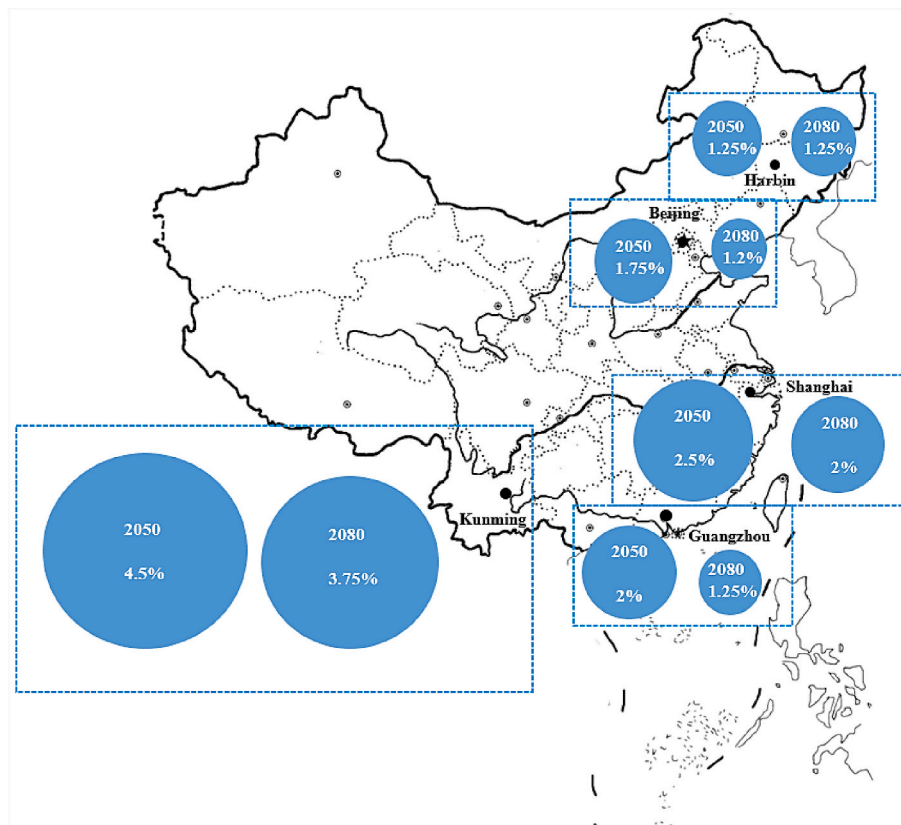

Fig. 8. The change proportion of the overheating hours - comparative results based on the Case600FF and the Case650FF for five selected cities in the 2050s and 2080s.

longer and warmer summers. The effect of night ventilation on overheating reduction increased with the drop in emissions in the 2050s and 2080s, and night ventilation was significantly more successful in lowering overheating in the 2050s compared to the simulation of the 2080s.

4.3. The influence of night ventilation with the heavyweight thermal mass on overheating

Fig. 9 highlights the positive effect of night ventilation in reducing overheating under the use of heavyweight thermal mass. The comparison of the four cities, Harbin, Beijing, Shanghai, and Guangzhou, shows that night ventilation is able to decrease overheating hours by as much as 20%–30%. In Fig. 10., the average overheating hours in these cities decreased by 21.75%, 23%, 30% and 22.5%, respectively, in the 2050s. The area of Kunming obtained the highest significant result of all the simulations. In this result, the average overheating hour decreased by 63.75% through the night ventilation, and the result in the 2080s stayed within the trend. Consequently, this finding demonstrates that in temperate areas, using heavyweight thermal mass and night ventilation may significantly reduce building overheating.

Moreover, this graph also shows that the average overheating hours in the 2050s were lower than in the 2080s. The effect of night ventilation in decreasing overheating started to decrease with an increase in GHG emissions, this was showcased using varying GHG emission scenarios.

5. Discussion of results

The overheating above 28 °C can be reduced by regulating the thermal mass and night ventilation of the building in different climates in China. The overheating hours are correlated with the cooling needs of the building; the higher the number of the overheating hours, the more the energy and carbon emissions will be generated, and the more the potential for high emission scenarios will be (Jimenez-Bescos, 2017). As suggested from the previous results, buildings under different climates have different effects on reducing overheating through thermal masses.

According to the simulation results in three selected cities (i.e., Harbin, Beijing and Shanghai), buildings with high thermal masses could be more resistant to the overheating, while the simulations in Kunming and Guangzhou proved that buildings could be more suitable with low thermal masses in warm climates. The results also explain an interesting phenomenon in some rural areas of China. Prior to the implementation of the uniform building standards, the walls of buildings in northern China had been generally thicker than those in the south. In China, some cities located in severe cold and cold climate zones, the thickness of building materials is generally thicker, which contain thicker insulation layers to prevent the loss of indoor heat in winter, therefore, in these cities, the selection of building materials normally choose heavyweight thermal mass materials. However, in southern Chinese cities, some materials exhibiting a lower thermal mass are used more frequently, and even bamboo buildings can be found in some areas.

Table 8 compares two cases with the night ventilation but different thermal masses in each simulated city. The comparison result revealed that in the long term, the combination of the thermal mass and the night ventilation may be more appropriate in decreasing building overheating.

Overheating in buildings is receiving greater attention due to global warming. This study focused on the building overheating in the 2050s and 2080s and indicated that the average overheating duration in 2050s was lower than that in 2080s, as expected from rising temperatures due to global warming. Existing results revealed the effectiveness of thermal mass and night ventilation in reducing the building overheating hours; however, as GHG emissions increased, the beneficial effect of thermal mass could be greatly reduced due to the risen outdoor temperatures (Jimenez-Bescos, 2017; Pfaffert et al., 2003).

Among the selected cities in this study, the simulation results for Kunming, located in the temperate climate are almost consistent with those of the other cities, especially in the high thermal mass buildings with the night ventilation that remarkably reduced the overheating time. These results confirmed that these two strategies differ in their ability to reduce the overheating hours in different climates.

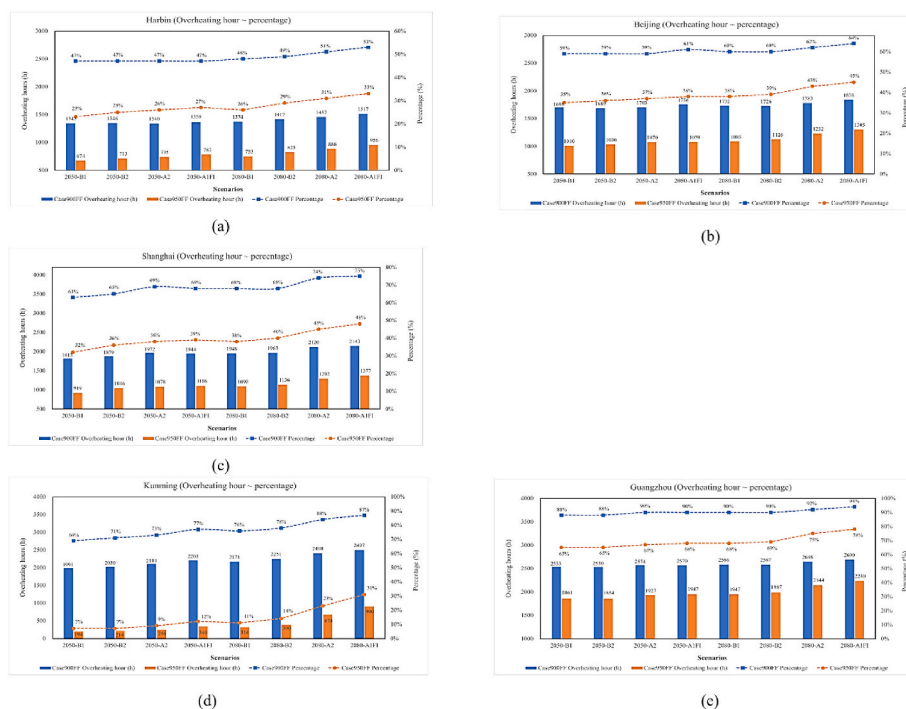

Fig. 9. Comparative findings of Case900FF and Case950FF in five selected cities in different scenarios in the 2050s and 2080s based on the number of overheating hours and the percentage of overheating hours in 2871 total working hours.

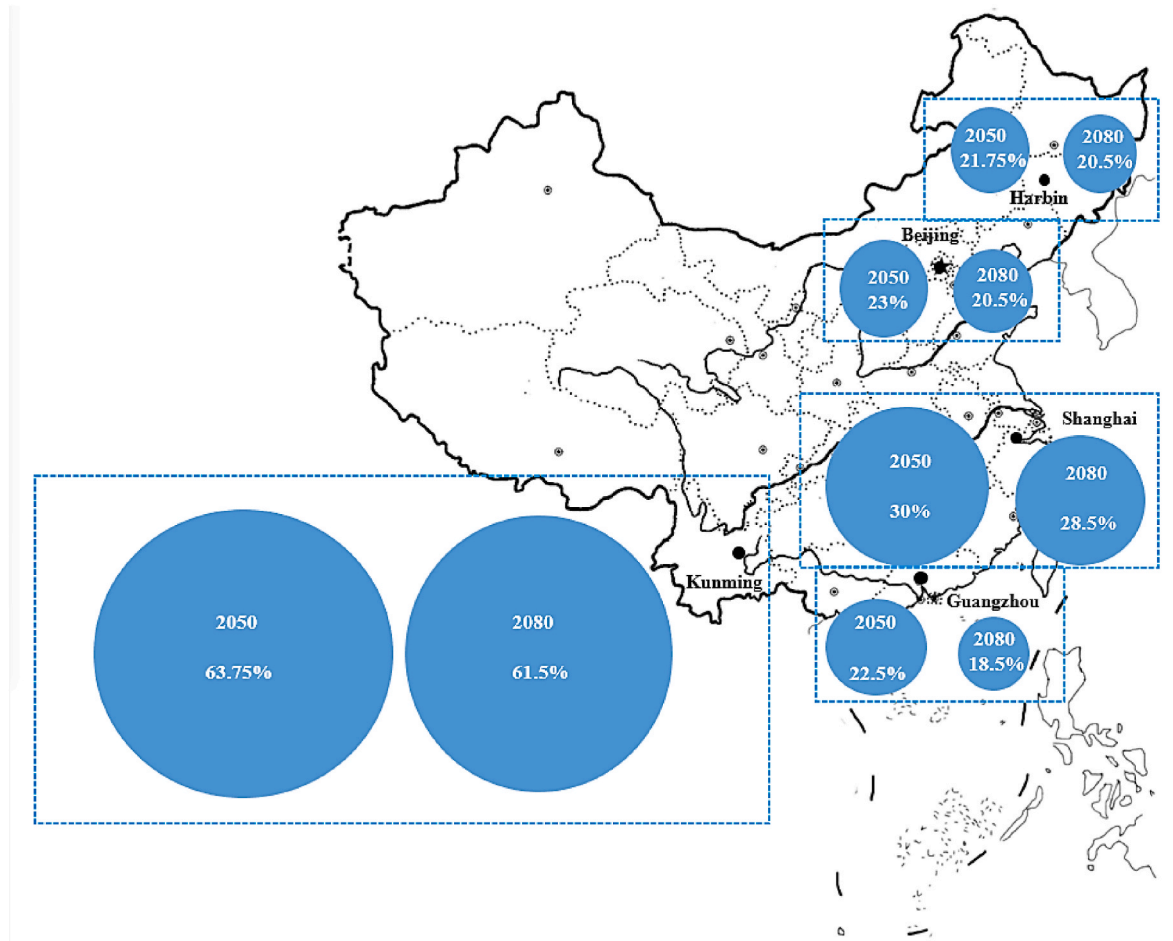

Fig. 10. The change proportion of the overheating hours - comparative results based on the Case900FF and Case950FF for five cities selected in the 2050s and 2080s.

Table 8

Comparison of overheating hours for the Case650FF and the Case950FF in different cities based on the future weather conditions.

Cities	Cases	Scenarios							
		2050s				2080s			
Harbin	Case650FF	1442	1460	1465	1499	1485	1503	1538	1581
	Case950FF	674	713	735	782	753	825	886	956
Beijing	Case650FF	1936	1927	1959	1967	1965	1947	1997	2046
	Case950FF	1010	1036	1070	1079	1085	1126	1232	1305
Shanghai	Case650FF	1909	1984	2018	2022	2015	2029	2113	2140
	Case950FF	919	1046	1078	1106	1090	1136	1292	1377
Kunming	Case650FF	1413	1432	1442	1484	1463	1508	1661	1776
	Case950FF	194	214	246	340	314	390	674	900
Guangzhou	Case650FF	2353	2353	2396	2393	2406	2410	2489	2547
	Case950FF	1861	1854	1927	1947	1947	1987	2144	2240

6. Conclusion and future works

This study focused on understanding the issue of overheating within buildings across different climate zones of China under future weather conditions by using the Energyplus tool. The aim was to evaluate the positive impact of thermal masses and night ventilation on reducing overheating. Lightweight and heavyweight thermal mass were evaluated. The study highlighted a relationship between overheating and climate conditions after comparing the results of overheating hours under different thermal masses of buildings.

Without using the night ventilation, purely changing the thermal mass, the use of heavyweight thermal mass materials is able to reduce overheating hours in Harbin, Beijing and Shanghai (which are located in

severe cold, cold and hot summer cold winter climate) by 5.25%, 10% and 5% respectively. We suggested in these regions, the designers should give priority to lightweight thermal mass materials. However, in Kunming and Guangzhou, the building overheating hours were not reduced when high thermal mass was employed. For Kunming, with a 17.5% increase by using the heavyweight thermal mass materials. For the severe cold, cold and hot summer cold winter regions, it is feasible to choose building materials with high thermal masses. In contrast, in some regions where the average annual temperature is higher, the preference is for building materials with low thermal masses. Hence, this clearly shows that thermal masses can have varying impacts on reducing overheating and that the appropriate thermal mass materials must be incorporated.

Meanwhile, the effective integration of night ventilation and thermal mass play an important role in reducing building overheating in all regions, especially for the heavyweight thermal mass and the night ventilation. The lightweight thermal mass with night ventilation reduced overheating hours by about 1.5 percent to 4 percent with negligible mitigation effects; however, in heavyweight thermal mass cases, assisted by night ventilation, overheating hours in each city decreased significantly, for Harbin, Beijing, Shanghai and Guangzhou, the efficiency of building overheating mitigation reached 21.75%, 23%, 30% and 22.5% respectively. Specifically, the overheating hours declined by around 60% in Kunming, which is present in a temperate climate. These findings show that night ventilation and heavyweight thermal substances may reduce overheating in a significant manner.

Compared with the simulating results between 2050s and 2080s, it is obvious that the overheating of buildings in 2080s is more serious than in 2050s due to global warming, and the use of night ventilation and thermal mass is more effective in improving the overheating of buildings in 2050s. These results should be considered in the design of new buildings to avoid reductions in indoor thermal comfort due to the overheating of buildings in the future. This study emphasized that relevant researchers should stress the relationship between thermal masses and the night ventilation in future climates.

Future research is needed to fully investigate the impact of thermal masses and night ventilation in the future due to the subsequent climate change that will occur. In this study, the validated models and material information are based on the BESTEST standard (Robert and Michael, 2004), however the investigation of the thermal mass and night ventilation influence on specific building design and configurations in different cities will also be carried out in future research. Moreover, it is important to study other cooling technologies to decrease overheating. Further research will look into the implementation of the outcome of this paper into the building construction regulation in China to provide practical applications with Chinese regulations in each region of the study.

Declaration of competing interest

The authors declare that they have no known competing financial interests or personal relationships that could have appeared to influence the work reported in this paper.

Acknowledgement

The authors would like to express their gratitude to the University of Nottingham's Department of Architecture and Built Environment for providing the facilities for modelling and simulations.

References

- Alhindawi, I., Jimenez-Bescos, C., 2020. Assessing the performance gap of climate change on buildings design analytical stages using future weather projections. *Environmental and Climate Technologies* 24, 119–134. <https://doi.org/10.2478/rtuct-2020-0091>.
- Amos-Abanyie, S., Akuffo, F.O., Kutin-Sanwu, V., 2013. Effects of thermal mass, window size, and night-time ventilation on peak indoor air temperature in the warm-humid climate of Ghana. *Sci. World J.* 1–9. <https://doi.org/10.1155/2013/621095>, 2013.
- ASHRAE, 2017. ANSI/ASHRAE Standard 55-2017 Thermal Environmental Conditions for Human Occupancy. American Society of Heating, Refrigerating Air Conditioning Engineers (ASHRAE), Atlanta, GA, USA, 2017, n.d.
- Birchmore, R., Davies, K., Etherington, P., Tait, R., Pivac, A., 2017. Overheating in Auckland homes: testing and interventions in full-scale and simulated houses. *Build. Res. Inf.* 45, 157–175. <https://doi.org/10.1080/09613218.2017.1232857>.
- Burch, D.M., Walton, G.N., Cavanaugh, K., Licita, B.A., 1986. The Effect of Interior Mass Surfaces on the Space Heating and Cooling Loads of a Single-Family Residence (No. NBS IR 86-3377). National Bureau of Standards, Gaithersburg, MD. <https://doi.org/10.6028/NBS.IR.86-3377>.
- Cao, X., Dai, X., Liu, J., 2016. Building energy-consumption status worldwide and the state-of-the-art technologies for zero-energy buildings during the past decade. *Energy Build.* 128, 198–213. <https://doi.org/10.1016/j.enbuild.2016.06.089>.
- CIBSE, 2005. The chartered institution of building services Engineers (CIBSE) TM36. In: *Climate Change and the Indoor Environment: Impacts and Adaptation*. The Chartered Institution of Building Services Engineers, London, 2005., n.d.
- CIBSE, 2006. The chartered institution of building services Engineers (CIBSE). In: *CIBSE Guide A: Environmental Design*. The Chartered Institution of Building Services Engineers, London, 2006., n.d.
- CIBSE, 2013. The Chartered Institution of Building Services Engineers (CIBSE) TM52. *The Limits of Thermal Comfort: Avoiding Overheating in European Buildings*. The Chartered Institution of Building Services Engineers, London, 2013., n.d.
- CIBSE, 2017. The Chartered Institution of Building Services Engineers (CIBSE) TM59. *Design Methodology for the Assessment of Overheating Risk in Homes*. The Chartered Institution of Building Services Engineers, London, 2017., n.d.
- DOE, 2021. U.S. Department of energy's (DOE) building technologies office (BTO) [online], Available: n.d. <https://www.energyplus.net/weather>.
- Gb50176-2016, 2016. GB50176-2016. Code for Thermal Design of Civil Building. Chinese Construction Industry Publisher n.d.
- Gb50178-93, 1993. Standard on Division of Climate Zones for Buildings. Chinese Construction Industry Publisher, pp. GB50178-G50193, 1993., n.d.
- Guo, H., Huang, L., Song, W., Wang, X., Wang, H., Zhao, X., 2020. Evaluation of the summer overheating phenomenon in reinforced concrete and cross laminated timber residential buildings in the cold and severe cold regions of China. *Energies* 13, 6305. <https://doi.org/10.3390/en13236305>.
- Hamdy, M., Carlucci, S., Hoes, P.J., Hensen, J.L.M., 2017. The impact of climate change on the overheating risk in dwellings—a Dutch case study. *Build. Environ.* 122, 307–323. <https://doi.org/10.1016/j.buildenv.2017.06.031>.
- Hatvani-Kovacs, G., 2019. Heat stress resistant residential design in Australia. In: *Environment*, vol. 19. Australian Institute of Architects).
- Robert, H. Henninger, Michael, J. Witte, 2004. 'EnergyPlus Testing with ANSI/ASHRAE Standard 140-2001 (BESTEST)' Ernest Orlando. Lawrence Berkeley National Laboratory (n.d).
- Jentsch, M.F., Bahaj, A.S., James, P.A.B., 2008. Climate change future proofing of buildings—generation and assessment of building simulation weather files. *Energy Build.* 40, 2148–2168. <https://doi.org/10.1016/j.enbuild.2008.06.005>.
- Jentsch, M.F., James, P.A.B., Bourikas, L., Bahaj, A.S., 2013. Transforming existing weather data for worldwide locations to enable energy and building performance simulation under future climates. *Renew. Energy* 55, 514–524. <https://doi.org/10.1016/j.renene.2012.12.049>.
- Jiang, A., Liu, X., Czarniecki, E., Zhang, C., 2019. Hourly weather data projection due to climate change for impact assessment on building and infrastructure. *Sustain. Cities Soc.* 50, 101688 <https://doi.org/10.1016/j.scs.2019.101688>.
- Jimenez-Bescos, C., 2017. An evaluation on the effect of night ventilation on thermal mass to reduce overheating in future climate scenarios. *Energy Proc.* 122, 1045–1050. <https://doi.org/10.1016/j.egypro.2017.07.476>.
- Li, L., 2021. Integrating climate change impact in new building design process: a review of building life cycle carbon emission assessment methodologies. *Cleaner Engineering and Technology* 5, 100286. <https://doi.org/10.1016/j.clet.2021.100286>.
- Lomas, K.J., Porritt, S.M., 2017. Overheating in buildings: lessons from research. *Build. Res. Inf.* 45, 1–18. <https://doi.org/10.1080/09613218.2017.1256136>.
- Morgan, C., Foster, J.A., Poston, A., Sharpe, T.R., 2017. Overheating in Scotland: contributing factors in occupied homes. *Build. Res. Inf.* 45, 143–156. <https://doi.org/10.1080/09613218.2017.1241472>.
- Peacock, A.D., Jenkins, D.P., Kane, D., 2010. Investigating the potential of overheating in UK dwellings as a consequence of extant climate change. *Energy Pol.* 38, 3277–3288. <https://doi.org/10.1016/j.enpol.2010.01.021>.
- Pfafferott, J., Herkel, S., Jäschke, M., 2003. Design of passive cooling by night ventilation: evaluation of a parametric model and building simulation with measurements. *Energy Build.* 35, 1129–1143. <https://doi.org/10.1016/j.enbuild.2003.09.005>.
- Reilly, A., Kinnane, O., 2017. The impact of thermal mass on building energy consumption. *Appl. Energy* 198, 108–121. <https://doi.org/10.1016/j.apenergy.2017.04.024>.
- Shaviv, E., Yezioro, A., Capeluto, I.G., 2001. Thermal mass and night ventilation as passive cooling design strategy. *Renew. Energy* 24, 445–452. [https://doi.org/10.1016/S0960-1481\(01\)00027-1](https://doi.org/10.1016/S0960-1481(01)00027-1).
- Stevens, V., Kotol, M., Grunau, B., Craven, C., 2016. The effect of thermal mass on annual heat load and thermal comfort in cold climate construction. *J. Cold Reg. Eng.* 30, 04015002 [https://doi.org/10.1061/\(ASCE\)CR.1943-5495.0000092](https://doi.org/10.1061/(ASCE)CR.1943-5495.0000092).
- Yau, Y.H., Hasbi, S., 2013. A review of climate change impacts on commercial buildings and their technical services in the tropics. *Renew. Sustain. Energy Rev.* 18, 430–441. <https://doi.org/10.1016/j.rser.2012.10.035>.