

Master of vocational education

Mayp 2006

From a closed mind to an open mind
through
an action research project

How do I improve my practice?

By Elisabeth Grande

Department of vocational education

2010



Acknowledgements

“We realize that action research is not a teaching strategy for gaining better educational results, neither is it a preparation for life: it is life itself”.

[http://ejolts.net/files/journal/1/1/Bognar_Zovko1\(1\).pdf](http://ejolts.net/files/journal/1/1/Bognar_Zovko1(1).pdf) (15.03.10)

This is exactly what I feel after reading and working with action research. It is the end of this project but it's not the end of my understanding of how I would use action research philosophy in my practice.

My thanks go to Hiak who brought Jack Whitehead for a presentation in action research.

People say that I'm "whiteheaded" and I'm indeed. Thank you, Jack.

I have to thank my class who has put up with me and my "research".

To Kjartan, my supervisor, for comforting words and kicks. To, my hidden bicycle Anita, for good conversations and for always answering the phone. To my good friend and translator, Pauline, whom I think hate words like standards of judgment, claims on knowledge, ontology and epistemology. And to Mette, who has done a great job with my "was and were".

To Janikke for doing my teaching over a period.

A special thank to my husband, Roger, who has done everything in and outside the house so I could write, and to my kids, Amalie and Kristian who practically lost their mom for a while.

To the rest of my family and friends, thank you.

A special thanks to Brian for helping me with photoshop.

If there is any fault in my understanding of action research it's certainly not any other's fault than mine. I would remind the reader that English isn't my native language, and I ask that anyone who finds mistakes in this text has that in mind.

And thanks to everyone else in my long process.

It is the quality of the relationship between teacher and student that is the crucial in any kind of teaching.

Thomas Gordon 1974

SAMMENDRAG

Hvordan har jeg forbedret min praksis og lagt tilrette for at mine elever kan forbedre sin praksis. Med fokus på:

- endringer i holdninger
- miljø
- faglige oppgaver

Å forbedre.... gjøre bedre. Jeg har smakt på ordet og det smake godt, men også som mye arbeid. Hvordan forbedret jeg min praksis. Jeg brukte aksjonsforskning fordi dens kjennetegn er forskning gjennom konkrete handlinger. Whitehead og McNiff (2006) sier at aksjonsforskning starter med et behov om å forbedre sin praksis og at problemstillingen ofte stiller spørsmål om hvordan man skal gjøre det. Jeg startet dette aksjonsforskningsprosjektet med et ønske om å forbedre min praksis ved å først og fremst å endre klassemiljøet.

Utgangspunktet for aksjonsforskningen var at jeg hadde en uro og denne uroen hadde jeg på flere områder. Men særlig på det området som gjelder våre mellom menneskelige forhold. Læreren hadde en dårlig holdning og elevene hadde dårlige holdninger. *De skrek meg oppi ansiktet, de skrek til hverandre og noen ganger skrek jeg tilbake til dem.* Slik kunne vi ikke ha det.

Dewey hevder at å ta hverandre på alvor og være åpne og gjestfrie mot hverandre ligger naturlig for oss, og bekrefter dermed det behovet jeg hadde for å være åpen mot mine elever for å involvere dem i prosessen.

Hva er dette vi kaller skolemiljøet, klassemiljøet, det psykososiale miljøet, læringsmiljøet, læringsarenaen. Jeg tror kanskje at man kan påvirke det på flere måter. Ikke jeg, men vi og kanskje aller mest elevene selv. Sammen med elevene, gjennom aksjoner, vil jeg legge tilrette for at elevene skal forstå og oppdage selv hvordan de kan forandre seg og sitt klassemiljø. Gjennom en av aksjonen kalt tre pedagogiske soler gir elevene uttrykk for dette slik: *Jeg har oppdaget at vi forstår hverandre bedre... jeg føler at vi i klassen tenker likt... jeg opplever at vi har mange like meninger.* Elevene oppdager selv at de ikke er så forskjellige som de trodde, at de faktisk tenker likt og deler samme meninger. Å oppdage selv kommer fra Grendesads konfluente pedagogikk. Det heter ”å lære er å oppdage”. Det å kunne legge tilrette for at elevene skal kunne lære selv er en utfordring innenfor rammene som skolen setter, men ingen umulighet.

SUMMARY

How do I improve my practice and facilitate for my students in order to improve their own practice? With a focus on facilitating:

- change in attitudes
- environment
- subject tasks

To improve...making better. I have tasted this word and it does taste good, but it also tastes like effort. How did I improve my practice? This is what I-m going to discuss and illustrate from different angles. How have I improved my practice? How have the pupils improved their practice and all this with focus on attitude, environment and subject tasks.

Whitehead og McNiff (2006) say that action research starts with a need to improve your practice and that the way of presenting the problem is how to do it. I started this action research with a wish to improve my practice first and foremost by changing the class environment. The starting point for my action research was that I had a concern and this concern I had on several fields, but particularly on the field concerning our interpersonal relationships. The teacher had a bad attitude and the pupils had bad attitudes. *They shouted at me and at each other and sometimes I answered them in the same way.* We simply could not go on that way. John Dewey's theories of keeping the door ajar and a hospitable thought also supports this. Dewey claimed that taking each other seriously and being open and hospitable to each other is natural for us, and thus verifies the need I felt for being open in relation to my pupils and to involve them in the process.

What is this called the school environment, class environment, the psychosocial environment, learning environment, learning arena. I think that we can influence it in several ways. Not me, but we, and perhaps most of all the students themselves. Through one of the actions called three pedagogical suns teaching expresses the students themselves this way: *I've discovered that we understand each other better ... I feel that we are thinking a like in this class ... I experience that we have many similar opinions.* Students discover themselves that they are not as different as they thought, that they are actually thinking much the same and share similar opinions. To discover for you come from Grendstads confluent education. He writes "to learn is to discover". Being able to facilitate for the students to learn themselves is a challenges within the frames that the school sets, but not impossible

Contents

Acknowledgements	2
SAMMENDRAG	4
SUMMARY	5
INTRODUCTION.....	10
Chapter overview	13
1 WHAT IS MY CONCERN?	15
1.1 My experience with students and teenagers	15
1.2 My values and standards of living.....	16
1.3 I dig deeper into my concern.....	16
1.4 What about me?.....	18
1.4.1 Methodology	18
1.4.2 The action research circle.....	20
1.4.3 Different methods.....	21
1.4.4 A change.....	23
1.4.5 Ontology and epistemology	25
1.5 Ethical frames.....	27
1.6 My way of presenting the problem.....	28
1.7 My time timeline	29
1.8 Summary	29
2 WHY AM I CONCERNED?	30
2.1 What is the nature of theory	30
2.1.1 My ideas about theory	31
2.1.2 My ideas about knowledge.....	31
2.1.3 My ideas about logic	33
2.1.4 My ideas about forms of representation	34
2.2 Relationships between theory and practice	34
2.3 My personal context	35
2.4 My locational context.....	36
2.5 My policy context.....	37
2.6 Values and context	38
2.7 Summary	38

3	WHAT EXPERIENCES CAN I DESCRIBE TO SHOW WHY I AM CONCERNED? ..	39
3.1	The situation initially	39
3.2	Results of my first action	40
3.2.1	Summary results	42
3.2.2	Claim on knowledge and significance of learning	42
3.4	Summary	43
4	WHAT KIND OF DATA WILL I GATHER TO SHOW THE SITUATION AS IT UNFOLDS?.....	44
4.1	Which data and who gathers them?.....	44
4.2	Focusing on me	45
4.3	Focusing on others	46
4.4	How are data gathered?	47
4.5	Summary	48
5	HOW DO I EXPLAIN MY EDUCATIONAL INFLUENCE IN LEARNING?	49
5.1	Sorting and categorizing the data	49
5.2	Analyze the data for meaning.....	49
5.3	Identifying criteria and standards of judgment	50
5.4	My standards of judgment.....	51
5.5	Significance of my learning	52
5.6	Summary	53
6	HOW DO I SHOW THAT ANY CONCLUSIONS I COME TO IS REASONABLY FAIR AND ACCURATE?.....	54
6.1	Establishing validity and legitimacy	54
6.2	Power-constituted contexts	55
6.3	Social validity.....	55
6.4	Personal and social validation	56
6.5	My way and Habermas's.....	57
6.7	Summary	58
7	WHAT COULD I DO AND WHAT DID I DO? PART I.....	59
7.1	My second action- three pedagogical suns.....	59
7.1.1	My planning	60
7.1.2	What did I do.....	60
7.1.3	My reflection:.....	61

7.1.4 Students log:.....	62
7.1.5 Significance of learning:	63
7.1.6 My claim on knowledge	64
7.1.7 Changes:.....	64
7.2 My third action - student participation.....	65
7.2.1 My planning:	66
7.2.2 What did I do.....	66
7.2.3 Reflection:	68
7.2.4 Significance of learning:	69
7.2.5 My claim on knowledge:.....	70
7.2.6 Changes:.....	71
7.3 My fourth action – our roles through the day.....	71
7.3.1 My planning:	72
7.3.2 What did I do?.....	73
7.3.3 Reflection:	75
7.3.4 Significance of learning:	75
7.3.5 My claim on knowledge:.....	76
7.3.6 Changes:.....	76
7.3.7 Next meeting the following day:	76
7.3.8 Reflection on the logs:.....	78
7.3.9 Significance of learning	78
7.3.10 Claim on knowledge:	78
7.4 My fifth action – conflict and cooperation.....	79
7.4.1 My planning:	80
7.4.2 What did I do?.....	80
7.4.3 This is what my students wrote in their log	83
7.4.4 Reflection:	83
7.4.5 Significance of learning:	84
7.4.6 Claim of knowledge:	84
7.4.7 Change:.....	84
8 WHAT COULD I DO AND WHAT DID I DO? PART II.....	85
8.1 My sixth action- swim or drown	85
8.1.1 My planning	86
8.1.2 What did I do?.....	86
8.1.3 Reflection	86

8.1.4 Reaction from students	87
8.1.5 Significance of learning	88
8.1.6 Claim on knowledge.....	89
8.1.7 Changes	89
8.2 My seventh action – my questionnaire.....	89
8.2.1 The questionnaire	90
8.2.2 Changes to the questionnaire.....	91
8.2.3 What use did I have of this questionnaire	93
8.2.4 Students say:.....	93
8.3 My eight action – my first free task	94
8.3.1 My planning and what did I do	95
8.3.2 Reflection	96
8.3.4 Changes	97
8.3.4 Significance of learning	97
8.3.5 Claim of knowledge	97
8.3.6 To illustrate a fairytale	97
8.3.7 Summary	101
9 ESSAY HOW DO I IMPROVE MY PRACTICE.....	102
10 HOW DO I EVALUATE THE EVIDENCE-BASED ACCOUNT OF MY LEARNING?	115
10.1 Comprehensible – Is my account comprehensible?	115
10.2 Truthful – is my account truthful?.....	116
10.3 Sincere – is my account sincere	117
10.4 Appropriate - is my account appropriate?	118
10.5 Can we believe the story that is told?.....	118
10.6 Summary	118
11 HOW DO I MODIFY MY CONCERNS, IDEAS AND PRACTICE IN THE LIGHT OF MY EVALUATION?.....	119
11.1 Modifying my concerns	119
11.2 Modifying my ideas	119
11.3 Modify my practice	120
11.4 Do my research go on?.....	121
11.5 Summary	121
BIBLIOGRAPHY	122
Andre kilder:	124

INTRODUCTION

When I talk to Jack Whitehead he asks “what is your embodied knowledge”? I was surprised, because it struck something in me. And it got me thinking. I’m still thinking and I find it very difficult to answer his question. It feels like I confuse embodied knowledge with values. I mean that embodied knowledge and embodied values are different things. I imagine that knowledge contains experience, context, interpretation and reflection. I won’t go into an analysis of the concept of knowledge.¹ And ethical values contain e.g. such as human self-worth, freedom, integrity, tolerance, charity, faith, hope, love, justice, solidarity and humanity. I let this question be open and unanswered for now.

I can say something about my values and what I believe in. I believe in the good in people, in trust, fairness and honesty. That is what my mother says I need in this world. “If you are an honest person, things will go well for you in the world”, she often said when I was a child. But these are abstractions to me, and I’m not sure that I portray this in my living practice. How can I make these abstractions come alive in my real-life practice? How can I show that this is or should be embodied in my practice?

Through this thesis I will try to answer Jack’s questions among other questions. My research consists of several years of studies. However my data gathering is mostly from 2008 and 2009. My thesis is, in many ways, not traditional. In my thesis I will try to show the changes I have gone through, in my teaching procedures, and how that affects my students. I will show how I did my research together with my students in order to facilitate their possibility of influencing their environment. I will show that values such as trust, fairness and honesty affect my research and students’ everyday lives. I will also show how important I think it is for the students, that I show my values in this way. I want, through my research, to show that these values permeate what I do for the students and with the students. I also want to show

¹ but I can recommend reading a essay about knowledge written of Kristin Clement on this link.

http://www.snL.no/Kunnskap_%E2%80%93_av_Kristin_Clemet

that the way to this understanding is a long and winding road to walk. I do this because I have a fundamental wish for my students to have a safe² and constructive learning environment at school. However with the negative behavior they show, I doubt this is their experience. This affects not only the teacher and students but also the learning environment.

I know for sure that I probably won't find a sure answer with an action research project like this. I will try to find and claim knowledge through my research, I am not sure it's new, but it's new to me. Some knowledge is about interpersonal relationships and how we can use dialogue actively in school life in order to facilitate both social and academic environment.

But I know for sure that I have a greater understanding of action research now than before I started this project. I also think that this is a philosophical way of seeing the world. The deeper I understand the meaning of action research the more philosophical I feel. It also makes sense when I read McNiff and Whitehead (2009) who say that writing an action report is not just about professional education, it's more a philosophical stance toward the world, an attitude of enquiry that enables people to question and improve taken-for-granted ways of thinking and acting. After reading and understanding more of the action research processes I do agree.

My personal validation takes a form of self-evaluation. I rely on my own internal processes of critical reflection to valid my beliefs. I lean on Polanyi (1958) who says we can take a decision to understand the world from our own point of view as individuals claiming originality and exercising our judgment with universal intend. But it takes courage and determination and a sense of personal identity to persuade others to take you and your claims seriously. "Dislodging the stories can be difficult and scary, because it means actually changing the way you think, and once you have done this there is no going back. You make your eyes different". (Polanyi 1958:143) I will refer to some situations where I really have to stand for my meanings and also for my claims.

² It isn't shooting and guns at school, so what I mean is that their environment to be stable and calm, relaxed and safe.

I chose to do an action research project because action research's basic idea was that those who have and know the problem actively involves in the research process. I want to fully explore what I perceive as the free form of action research by letting something be intuitive and see what becomes apparent. When describing actions I will ask myself "How do I evaluate the influence of my actions in relation to my values and understanding". But I also plan, implement and reflect on actions when appropriate. This, I believe, is to use action research as a holistic research appropriate. I see myself as somewhat wiser along the path of action research, because my thinking, actions and opinions are challenged during the meeting with students, literature and dialogue with my peers. And therefore I often find it difficult to maintain focus in one direction when I do my research. I allow myself to embrace the unknown that comes to me and hope in this way to be as open-minded as Dewey says we are.

Since my thesis is a documentation of changes in me as an individual, and also how my teaching procedures have changed, and how that affects my students I write it in first person. But in Norway it's not a very used culture in the academia to have too many "I" in a thesis. For that reason I tend to mix both "I" and "we" together. Hopefully I would be true to myself and write "I" where it is supposed to be "I". If anyone would question this I would lean on McNiff and Whitehead. "You are the center of your action research, so you deconstruct your own thinking and action in order to help others to do the same". (McNiff and Whitehead 2009:14) Habermas (1987) also says when you use I as in a first-person sentence it means that the speaker is presenting himself in the expressive mode. "He takes on the role of self-presentation in such way that desires, feelings, intentions, beliefs, and so forth uttered can be ascribed to him".(Habermas 1987:104)

I am a teacher for a freshman class fall 2008. I had some experience in higher secondary school and 10 years' praxis at primary school. I teach two subjects and that's why I had many lessons at school with my class.

I use Whitehead and McNiff's book Action Research Living Theory (2006) and their ten questions to structure my thinking. This is also my method for my research. I write more about this in chapter 1.4.1 Methodology and method.

Chapter overview

Chapter 1 What is my concern

This chapter contains my framing of my thesis. I present my first concern which contains worries about attitudes, environment and subject task. I present my values and standard of living. I outline a change in my pedagogical view and my methodology. I talk about my ethical framing and finally I tell you about my research question.

Chapter 2 Why am I concerned

What is the nature of theory? Here I write about my ideas about theory, knowledge and logic. I tell you about my context I do my research in and I tell you why I am concerned.

Chapter 3 What experiences can I describe to show why I am concerned?

I tell you about a story before my actions. And what happen to initializes for my first action. I show you an environment which isn't good and the results of my first action, my claim on knowledge and my significance of learning.

Chapter 4 What kind of data will I gather to show the situation as it unfolds?

In this chapter I am focusing on data. Which data do I need to gather and who can gather data. I say something about me, monitoring my action and learning and then I focus on others. I also say something about how I gather data through logs, survey and observations.

Chapter 5 How do I explain my educational influence in learning?

Here I write about sorting and categorizing my data. I tell how I analyze my data for meaning and identifying criteria and standards for judgment for my data. I also say something which kind of standards I use to do this.

Chapter 6 How do I show that any conclusions I come to is reasonably fair and accurate?

This chapter is about establishing validity and legitimacy. I show how I use Habermas criteria and outline my personal and social validation.

Chapter 7 What could I do and what did I do Part I

This chapter contains my actions which concerns the environment. Its five actions were we work with different themes. I use headlines as my planning, what did I do, reflections, significance of learning and claim of knowledge.

Chapter 8 What could I do and what did I do Part II

This chapter is about my actions which contains working on subject tasks. My concern was that the tasks were framed so strictly that the student couldn't reflect for themselves.

Chapter 9 Essay How to improve our practice

In this chapter I use essays to discuss did I improve my practice and did my students to improve their practice.

Chapter 10 How do I evaluate the evidence-based account of my learning ?

Here I use Habermas' criteria for evaluating my evidence-based account. Is my account comprehensible, truthful, sincere and appropriate. This I answer here.

Chapter 11 How do I modify my concerns, ideas and practice in the light of my evaluation?

In this chapter I outline what to do next with action research. I say something about how I modify my concerns. I say that new ones are coming along and it is my job to do research in my field so that both teachers and students can have a better environment.

1 WHAT IS MY CONCERN?

The concern takes place on several levels. It includes me, my concerns about my own attitude, my teaching procedures, it concerns my students' well being at school and the ongoing environment. I present my values and standards of living, my methodology and my action research circle. I describe my methods and outline my thought about a change in my pedagogical view, my ontology and epistemology. I frame this in the chapter ethical frames and I present my research question at last.

1.1 My experience with students and teenagers

Before I started my work on this thesis I had, after some years of experience with students or teenagers, not a very good opinion of them. I thought of them as lazy youths who had no interest in working for their results. They were often arrogant and rude. I had a general bad attitude when dealing with the students. I've never had my own home room class and previously I had dreams of being a nice teacher who played with the kids and comforted them if they hurt themselves. But as time passed that never happened and now I have a bad attitude to them, which is not in accordance with working with teenagers.

So when I started with my class autumn 2008 I met a bunch of nice looking kids. But some of them were wolves in sheep's clothing. They are from the same district, but from different schools. Most of them don't know each other. They were at the most 26 in the group and daily there was shouting, yelling and arguments between the students. They would even shout in my face and threaten me. All this confirmed my assumptions. Often I answered them in the same way they talked to me. My overriding concern is based on this.

In the Norwegian school system, we want to push students through the school system, but I feel that we don't care about the students as social beings. And there is no one who cares about the teacher either. This is my feeling and my opinion and I can't answer for what other teachers think about this matter. But such an environment doesn't create confident and independent people, you create an environment where students quit school and the teachers turn sick. That is no environment for successful learning, and it doesn't create responsible, thoughtful and caring young people. I do agree with Whitehead and McNiff (2006) when they say that in post industrialized cultures, schools tend to teach students to think in limited and

limiting ways. I also agree with Thomas Gordon³ (1979) who writes that the school instead of developing a sense of responsibility is controlling and dictating students at all levels at school, as if the students should not be trusted and have any ability to assume responsibility.

It surprises me that teachers say⁴ the same thing in 1974 (when the book came out in the original language), as I say today, 35 years later. Does that mean that the school, teachers or students haven't changed? Is it really so that the teachers are so conventional that we are not willing to change? I think this is quite scary.

1.2 My values and standards of living

Jack Whitehead says we are a living contradiction. When he asked me about my embodied knowledge I started to think. And despite of the fact that I had a bad attitude towards my students I find myself to be an optimist. I do believe in the good in people, in listening and in talking to people, in trust, fairness and honesty, and in being a safe and stable adult. I just didn't make this my living theory. I am a living contradiction because I have a set of values I deny myself in my practice. I didn't take the students or myself seriously. Later I was forced to deal with my students and myself in a manner that made us able to survive in our every day school life.

I would say that believing in the good in people, in listening and in talking to people, in trust, fairness and honesty, and in being a safe and stable adult are my values and my standards of living in my educational life. I hold many values but I don't need to talk about them now. How can I make these abstractions come alive in my real-life practice? How can I show that this is or should be embodied in my practice? My research focus will not only be on the students but also on myself. I need a change in my attitude as much as my students. I need to improve my practice in a way that makes both the teacher and students better.

1.3 I dig deeper into my concern

My first concern is about my students and me. I see that if they don't change and make it work at school, they probably don't have a full exam paper after finishing secondary high school. It is no secret that the dropout rates at high school are generally large. Over 30% drop out. According to Statistics in Norway 56% of the pupils in secondary high schools achieve

³ Original text on book: T.E.T Teacher Effectiveness training – Thomas Gordon 1974

⁴ Look at p. 18 which is about a teacher who describes his everyday life at work. His dread of each day, each lessons and he doesn't think that the pupils are nice.

academic or professional qualifications in the prescribed time, while 68% complete in 5 years (2008) (SSB).

The Royal Ministry of Education, Research and Church affairs - The Core Curriculum⁵ for primary, secondary and adult education in Norway says:

Opplæringens mål er å ruste barn, unge og voksne til å møte livets oppgaver og mestre utfordringer sammen med andre. Den skal gi hver elev kyndighet til å ta hånd om seg selv og sitt liv, og samtidig overskudd og vilje til å stå andre bi.
(Læreplan, generell del 1996: 5)

The aim of education is to furnish students with the tools they need to face the tasks of life, surmount its challenges together with others. Education is supposed to provide learners with the capability to take charge of themselves and their lives, as well as with the vigor and will to stand by others. The rate for drop out isn't in accordance with the nice words and goals that CC type.

My experience with my students, my concerns for myself and my students are in accordance with bad motivation, dropping out of school and not motivated students. The general part of CC is ambitious not only on students' behalf, but also on the teacher's behalf. It also demands a lot from both parts.

I want to pick out key words from CC to underpin what I mean: productive work, develop skills, skills to cope with changing environments, provide attitudes and knowledge. The education must accustom students to take responsibility - to consider the implications for others of their own actions and judging the actions with ethical awareness. The education's purposes are to expand the children and young people's abilities to acquire knowledge and experience, empathy, expression and participation.

Opplæringen må fremme demokrati, nasjonal identitet og internasjonal bevissthet. Den skal utvikle samhørighet med andre folk og menneskenes felles livsmiljø, slik at vårt land blir et skapende medlem av verdenssamfunnet.
(Læreplan, generell del 1996: 5)

The education must promote democracy, national identity and global consciousness. It will develop solidarity with other people and common people's life environment, so that our country is a creative member of the international community. With this I mean that the

⁵ From now on just called CC. "Læringsplakaten 2006"-is a part of the law am from now on called Learning poster.

The National Curriculum for Knowledge Promotion in Primary and Secondary Education and Training (LK06) in Norwegian called Kunnskapsløftet (LK06)

education of young people requires a lot of both teachers and students. I am, as a teacher, supposed to create conscious people and the Norwegian society becomes increasingly complex and diverse. Since globalization and technological developments have led to shorter distances between countries, languages and customs, cultural expressions and impressions from other countries have come closer. The Norwegian society has become more multi-ethnic and multi-religious than before and the population is more complex and with a greater diversity in terms of cultural and religious identity. The school is perhaps the most apparent visible arena.

The purpose of an inclusive school has created an increased diversity in the student group. This is reflected in the classroom. We must respect that there is a difference in the classroom with such diversity and not try to shape all into the same form. As one of my students said *“we can respect everyone even if we are not best friends”*. Maybe teachers need to have a greater understanding and respect for the differences that can occur in a classroom.

Before I proceed, I will summarize what my concerns are. Firstly, I am concerned about our attitude towards each other. It seems that we need a stable, calm and good learning environment or else I am afraid that my students don't get their final exam paper. The second concern is about my teaching procedures and how I structure the tasks. I will approach this later in the thesis.

1.4 What about me?

Here I will outline my methodology, present action research and my action research circle. I describe my methods as log, survey and the model SØT. I present briefly a change in my pedagogical view and I outline my thoughts about ontology and epistemology.

1.4.1 Methodology

Methodology refers to a theory of how we do things. It refers to the process of generating theoretical understandings through research. I early asked such questions as “How do I improve my practice? Already when asking this kind of questions I have focused on the practitioners' research. And that question is close to action research. Tom Tiller (2004) said that it takes a lot of the researcher in action research. You should use your entire personal repertoire. When you connect action and participation to research, you can't participate only with the intellectual and cognitive part of yourselves. Feelings and the emotional demands more space than in conventional, distance and non-participatory research.

Maybe I didn't have a choice. I jumped into what I believed was action research. I will explain later that my understanding of action research methods increased with time, and that I, in the beginning of my project, probably didn't do action research but more social science research. And maybe that isn't right either, but a mix of several, and there among action learning. Today, when I more fully understand the action research method, I can say that this is a method that fits well with my new pedagogical standpoint. And I agree with Whitehead and McNiff (2006) who say it is more a philosophical standpoint.

What is a living theory methodology? When I start my thesis asking what? And how? I have already staked out a way to my methodology. The more I read about action research the more I came to understand that I didn't know so much about action research. But it intrigued me a lot. I will not in this short time fully understand the living theory methodology. I can just refer to what Whitehead says at <http://ejolts.net/node/7> (15.03.10) and adopt some of his view. He says that a disciplined process of problem-forming and solving is an action-reflection method. And one of the distinguishing characteristics of action research from action learning is that the researcher must make public the story of their research in a way that is open to others to evaluate its validity. A living theory methodology includes the processes of validation.

I like Whitehead and McNiff (2006) and Habermas (1987) who believe that we are participants in the same world. That we are interacting with each other and our interactions are processes of creating new knowledge, individually and collectively.

My methodology will also say something about my ontology and epistemology. I will write more about that in a later chapter. I use Whitehead and McNiff's (2006) 10 questions to keep the discipline and systematization in my thesis. But I recognize this as one of my methods as well as a part of my methodology. Here are the questions:

1. *What is my concern?*
2. *Why am I concerned?*
3. *What experiences can I describe to show why I am concerned?*
4. *What can I do about it?*
5. *What will I do about it?*
6. *What kind of data will I gather to show the situation as it unfolds?*
7. *How will I explain my educational influences in learning?*
8. *How will I show that any conclusions I come to are reasonably fair and accurate?*
9. *How do I evaluate the evidence-based account of my learning?*
10. *How do I modify my concerns, ideas and practices in the light of my evaluations?*

(Whitehead and McNiff 2006:89)

I use these questions as they are described and used as headlines in their book. I also use them as headlines in my thesis.

1.4.2 The action research circle

Action research often starts with a concern or questions about processes of democratic development. Whitehead and McNiff (2006) write that this process starts with a need to improve. I will in my process of improving, use an action research circle that explains how I do my actions in this research project. This circle shows how the *situation now* is and what makes the action to be initiated. I used this circle to frame and understand my actions through this project.

An action research circle is an ongoing circle. And it's the same with an action research project. I lean on Whitehead and McNiff (2006) who write that if you feel you reach an endpoint in your research, you need to look at your thinking that leads you to stop your journey. Hartviksen and Kversøy (2008) underpin this by calling it hermeneutic activities which is endless in nature. They find further support in Gadamer who claims that this is the ontological structure of understanding. So an action research project is not a project which can be completed and has a finite end.

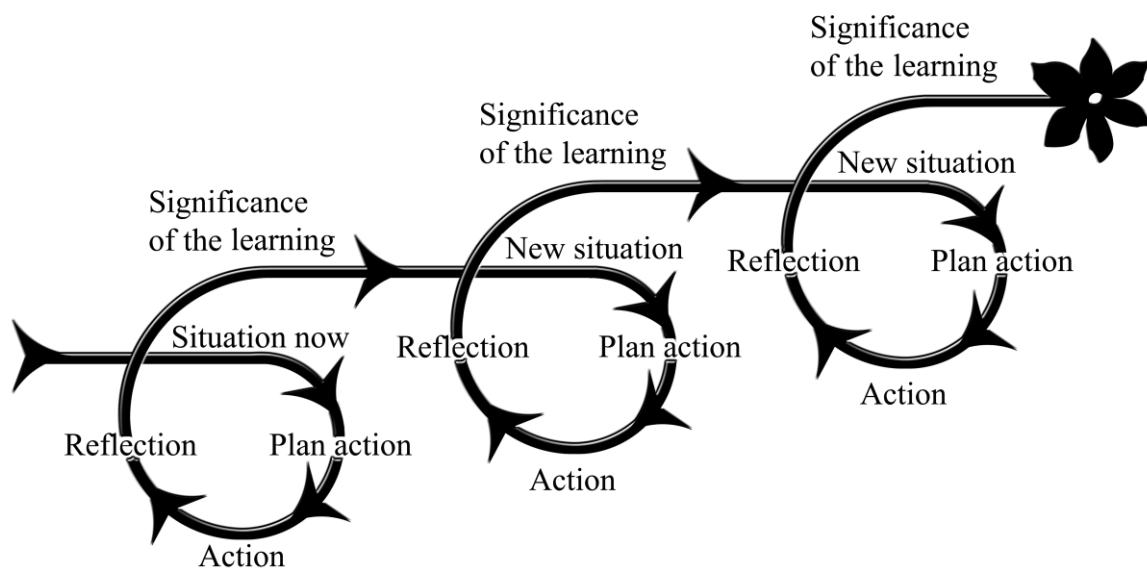

Figure 1 Action research circle
2010

Made for Elisabeth Grande by Brian Ngo

1.4.3 Different methods

Method refers to specific techniques we develop to gather data and find something out, such as multimedia, tape recordings and reflection notes and so on. I asked my students to write reflection notes, from now on called log. I collected logs from students and myself after each action we did. I also got a qualitative survey where I asked my students about the year they were participants in action research.

A log is an informal written method between teacher and student. In this way I can gather reflection and evidence. It also creates continuity between teacher and students which I think is important. I didn't want them to write a long story, only key words, because then they have to choose what was important for them in this action, and write that down. Most of them did. We agreed that our logs were supposed to be anonymous. But still I asked them to write their names on the logs. I wanted a discussion around what they would feel if I know who wrote what in the log. They told me it didn't matter if I knew who wrote what, but the log said something different. Some answered the log question what did I discover...? Like this:

I thought it was good to be anonymous, because then you can be more open.

And in the start the logs continued to be anonymous, but in the end some put their names to it and some didn't. I told them every time they wrote a log to remember it was anonymous.

I changed the questions in the log sometimes because of the answers students gave on the previous log. After my first action my students didn't use log. I wrote down my own reflections and what other teachers said to me. In the other actions my students wrote log. I didn't. I didn't use a fixed form that I handed out after each action, I wrote the various log questions on a learning platform called It's learning.

I used logs where I asked questions like *I felt....? I thought.....? I experienced.....?* When collecting data in this way I use what is called a phenomenological log. Phenomenology is a theory which says that only I can say something about my experiences. I am the source of my reality, my thoughts and feelings and only I know the whole truth about this.

Phenomenological logs aim to preserve the individual's understanding of the reality they find themselves in. And I am interested in what my students say about their reality in this action research project. At the same time I can use the logs to democratize the processes of interpretation. Hartviksen and Kversøy say that "I større grad data ivaretar den enkeltes perspektiv og opplevelser, i større grad demokratiseres fortolkningsprosessene". (2008:169)

Qualitative survey - I used a qualitative survey to ask my students how this year with action research was. I asked them about how the changes affected them and if they were more satisfied after the changes. I realize that making really good questions is difficult and next time I will present the survey to my friends to find good questions to ask. When you use a qualitative survey you get different kinds of data than by using log. Even if I use some of the same questions it seems that the students respond better while using log. I think it's easier to relate to three questions than two sheets with questions on both sides.

SØT- this is a model for gap-analysis. Hartviksen and Kversøy (2008) present this model as a development of other GAP-models. GROW is another model. I present some of the other concepts in their book as well.

This SØT-model has three steps:

S – Challenge the participants to describe the situation now.

Ø – Challenge the participants to describe the wish-situation or the situation of desire.

T – Challenge the participants to concretize the measures and commit to individual action.

It is the gap between S and Ø that contains all of the possibilities. This isn't an abyss, but a demonstration of possibilities.

The SØT-model is a non-finishing process and you can see the model as infinite. It's also a didactic tool for involving my students. You can use the model as a strategy, a tool, an action manner, an attitude or a way of thinking.

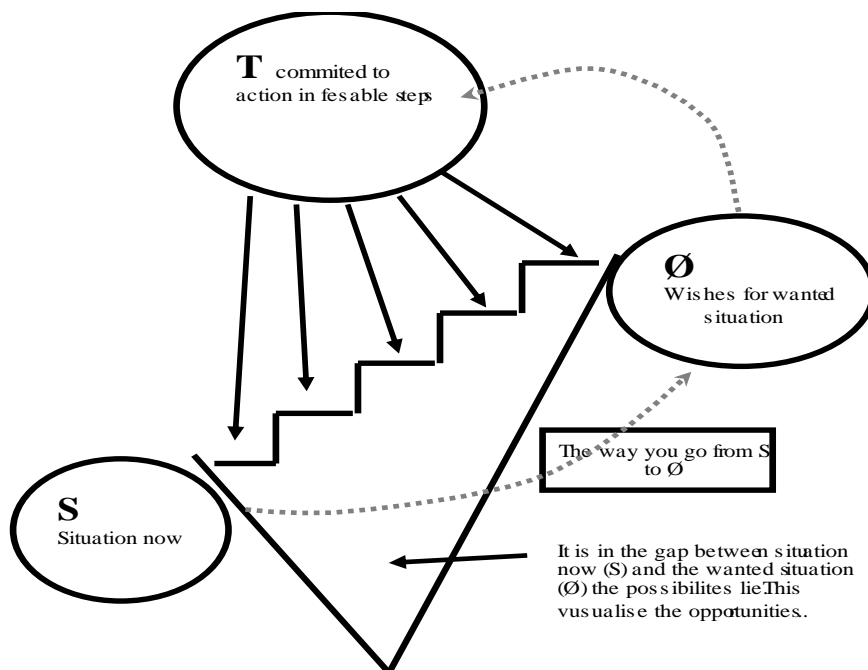

Figure 2 SØT model by Hartviksen and Kversøy

1.4.4 A change

I want to clarify where my pedagogical point of view is. I say one thing, but I do something else. Earlier in my thesis I was really honest when I said I didn't see much positive in the students before I got my own class. I like to think well of myself and it's hard to see myself as this simple-minded person.

As I described before there was a lousy environment in this class. I tried to teach my subject but I always found myself wondering about questions like: Where are the students now? Will anyone quit today? Will they yell at me or at each other? I felt that under these circumstances my teaching wasn't good. I can't point exactly on what it was, but I felt insecure and I didn't like that feeling. But I also felt challenged in a way, not only on my pedagogics, but on several levels in my working life. I talked to my colleagues about being challenged in their school life and how to handle being both a teacher and an individual. They have different thoughts about this. The first colleague said this: "I want to be absolutely strict in my teacher's role when I'm at school. But when the door closes behind me at 4 pm, I am a private person". My other colleague responded like this: "For me it is quite different, I want to have a coherent life. I try to be "me" at work and at home. I am "me" and I am a teacher, and it's

independent of whether I'm at home or at school". I know that I find myself close to the final perception. I think that I want a life as coherent as possible. I want to be Elisabeth and a teacher.

With this as a background, I see that my pedagogical view changes. I've previously wanted to be an oracle. I had, as many other teachers, been trapped in the myths about being a good teacher. Thomas Gordon (1979)⁶ argues that you lose your humanity if you want to live in a myth. But any person with respect for other people can't be an oracle. It is for me completely wrong. By that I mean that one must let students be allowed to learn for themselves and have faith in their capacity to do so. Previously, I must admit that I haven't held this view of my students and of course it is easier to do teaching when you can write on the board when students are quiet and make notes. Then I tend to think that this has been a good lesson for me and the students. But I can't say that I let students have the opportunity to influence their own learning when I do this kind of teaching.

My pedagogical view is changing to the better, I think. When I say I want a coherent life, I think that the values I have, should appear through my living theory and when I say that I will facilitate my students to influence their own learning. My previous thesis shows that I am concerned with customized training and I was determined to work with that subject in this thesis as well. But when I was given my class in higher secondary school I wanted to see what was becoming apparent. This had to do with both the academic content and the psychosocial environment as a basis for a good learning environment. The LK06⁷ writes that school should promote customized training and varied approaches to the themes. Bachman and Hauge (2006) write that there are many definitions of the concept of customized training. And that this is difficult to use in school today because a lot of teachers see it just as a method for facilitated learning.

I was teaching in a way which wasn't satisfying to me as a teacher. I say it this way because it created uneasiness in me to work with students in the manner we did. We gave students strictly defined tasks, we let them think little for themselves and we always had a recipe for how they should solve the task. But we didn't really talk to the students. My interest in talking to the students increased. Pupil participation became very interesting. We need to have a closer dialogue with the students. They must be able to participate in decisions that affect

⁶ I refer to some myths, he writes about in his book on p.19

⁷ The National Curriculum for Knowledge Promotion in Primary and Secondary Education and Training (LK06)

them. In my work, I read Nils Magnar Grendstad *Å lære er å oppdage* (1986), to learn is to discover. Grendstad writes about confluent education and I thought this was close to my own way of thinking. Grendstad writes that confluent means: to bring together into one unit. It is a teaching method where the emotional, intellectual and psychomotor aspects of learning and teaching processes are integrated. I refer to research made in the USA⁸. Galyean has written about what kind of effects it has to work with confluent language curriculum on the oral and written communication skills. She used a confluent pedagogy to developed new skills in this area and about personal and interpersonal relationships.

In this way I can say my view has changed quite dramatically. I look at student participation as an important factor in my pedagogical vision, where “*to learn is to discover*” is important. I also believe that the human side of this, which is to listen and lead equal dialogue with the students, is important. Maslow with his model of basic needs writes that to be seen and taken seriously is an important need for humans. Hegel has a theory about this as well. He writes that the need for recognition (anerkjennelse) is stronger than the need to live. (Hartviksen and Kversøy 2008) That is something to have in mind when you talk to your students!

1.4.5 Ontology and epistemology

“Ontology is the philosophical study of the nature of being, existence or reality in general, as well as the basic categories of being and their relations”.

(<http://en.wikipedia.org/wiki/Ontology> 01.04.10) This is what Wikipedia says, and Whitehead and McNiff (2006) says in addition that our ontology influences how we perceive ourselves in relation to our environment, including other people.

I do believe I am an optimist. I do believe in the good in people, in listening and talking to people, of trust, fairness, honesty and being a secure and stable adult person. And when I read what Jack Whitehead and Jean McNiff write in *Action Research Living Theory* (2006) about their ontological values I feel I may never look at humanity that way. I am not as open-minded as they are. Or more precisely I never had to think about my ontological values and what this entails. As I read their book they explain ontology as how we perceive ourselves in

⁸ Galyean, Beverly C.: The effects of a confluent language curriculum on the oral and written communication skills, and various aspects of personal and interpersonal growth of a college French level one class. (PhD. unpublicated) University of California, Santa Barbara 1977.

McCharty, David N.: A confluent reading and English fundamentals curriculum: derivation, description and evaluation. (PhD unpublicated) University of California, Santa Barbara 1975. Among others in Grendstads book s. 243-245

relation to our environment, including other people. My ontological perspective tends to influence how I see other people, and also the kind of approach I adopt in research. Ontology helps us understand how and why we live our lives as we do. When I try to put words to my ontology I recognize that my ontology transforms into epistemology.

I believe in a good world and in the good in humans. I believe that we are interdependent. I believe that we want to do each other well and that taking care of each other is important. For me there is something fascinating about the existentialism. I like existentialism in relation to what they write about the sense and man's free will. Sartre (1993) says that reality is absurd and that it can't be understood through sense. You should use non-rational knowledge as faith, feelings, intuition and will and if you use common sense you will come to the conclusion that humans don't have free will. Since I think that humans have free will, this forces their belief that reason can't provide true knowledge. I add that I see the good in people and the world, but I also believe that humans have free will. And that we cannot always control the "world" through sense. Even Gadamer (2003) says that "Fertile human scientific acknowledgement seems almost akin to the artist's *intuition* than by the researcher's methodical mind". (Gadamer 2003:8) (My underscore).

I do agree with Whitehead and McNiff's concept of knowledge as existing in different forms. They also write that epistemology is connected with rationality and knowledge. I agree, but I will add that I think that knowledge can occur without due rationality. Even Einstein appreciated intuition. "The rational mind is a faithful servant, the intuitive mind a sacred gift". (<http://intuisjonsskolen.no> (09.0410))

I recognize as Whitehead and McNiff (2006) that knowledge is something I create in company with other people who are creating their own knowledge. We interact with each other and thus we can take the already existing knowledge and turn it into something better. Imsen (2009) says when Dewey writes about knowledge he says that knowledge is not reproduced, but reconstructed.

Stenhouse (Stenhouse in Whitehead and McNiff 2006) writes, and I do agree with Stenhouse, who says that factual knowledge can be formed as detailed goals. But there are more advanced learning methods such as thinking about and considering an independent basis of existing information. Stenhouse means it isn't possible to predict where the students' independent thinking goes.

I think I can create my own knowledge, in company with other people who are also creating their own knowledge. I recognize knowledge as existing in different forms. I recognize that my students see knowledge as existing in different forms. I see that my students and I have a lot of values in common, but we don't show them to each other. I see that I can do actions so my students and I together can create our knowledge. We put forward some claims of knowledge that can be judged and I see how valid we make those claims. We have some of the same understanding of logic because we see the real as rational. "Aim to show how you live your values in your practice!". (McNiff and Whitehead 2009:126) But I didn't do that in my practice. In this thesis I will show how I have changed my living theory and how that effected the students' environment.

1.5 Ethical frames

I wish my students well and not to do them any harm. That's why I keep the name of my students out of my thesis. I do not mention my school with name or my subject. I have asked my participants for permission to work together with them on different themes and I got a permission to collect logs anonymously. I have assured my students on confidentiality all the time. I also, when referring to what students say, keep them anonymous.

I have a permission to do this master program from the leadership at our school, and I have a written permission to do research together with my students as long as I keep them and my school anonymous.

I also want to maintain intellectual freedom. I need to take care, not only of me but of my participants as well. Have I facilitated for manipulating them in any way? Yes, in a way I have. But it isn't to do them any harm. To get the class to recognize that we needed to do something to improve both ourselves and the environment, I have initiated some measures to improve the learning environment. I had concerns about what was going on in the class and it's me who has initiated actions. I'm not sure if the claim had come from the class. In this way I have manipulated the class. But I have not in any way influenced their opinions.

Nevertheless, it is important in all teacher-student relationship that the teacher is aware of his power, and power influence.

1.6 My way of presenting the problem

My concern takes place on several levels. It includes me, my concern about my own attitude, and our attitude towards each other. It also concerns my student's well being at school and the ongoing environment. It seems that we need a stable, calm and good learning environment or else I am afraid that my students don't get their final exam paper.

Then my concern is about my teaching procedures and how I structured the tasks.

I will also say that my values are trust, fairness and honesty. It's important to me to be a stable adult for my students. I see that I am deprived of a lot of what I appreciate in education and my values at my workplace for different reasons. My research question is therefore:

How do I improve my practice and facilitate for my students in order to improve their own practice.

With a focus on facilitating:

- *change in attitudes*
- *interpersonal relationships*
- *subject-related tasks*

How can I make abstractions like trust, fairness and honesty come alive in my real-life practice?

How can I show that this is or should be embodied in my practice?

I recognize that I only can do changes for myself and that I only can influence and facilitate for students to make changes for themselves. But both parts can have the same focus.

In my thesis I will try to show the changes in me, in my teaching procedures, and how that affects my students. I will show how I did my research together with my students in order to facilitate their possibility to influence their environment. I will try to show that values such as trust, fairness and honesty affect my research and students' everyday lives. I will also try to show how important I think it is for the students, that I show my values in this way. I want, through my research, to show that these values permeate what I do for the students and with the students.

1.7 My timeline

Here I show you which period my actions go from. They started in august, fall 2008. I had my last action on the environment, action 5 in spring 2009. And my last action concerning the subject task, action 8 late fall 2009. This is to show that it take time to do action research.



1.8 Summary

What is my concern? In this chapter, I described my experience with students at the beginning of the school year. I have explained what environment we had and why I was concerned. I have clarified my values and standards of living and described my methodology, methods, ontology and epistemology. My educational view has changed and I will tell you how. I say something about the ethical side of doing action research and I formulate a research question.

2 WHY AM I CONCERNED?

Propositional theory is represented as written text on a page. This is propositional theory in the easiest way of thinking. Because a lot of theory is written text on pages, but not all theory is propositional of course. I will briefly repeat what propositional theory is. It contains statements about the way things are. “And tend to be grounded in a quest for certainty in the form of general statements in response to particular answers”. (Whitehead and McNiff 2006:31)

I primarily use Whitehead and McNiff's book *Action Research Living Theory* (2006) which introduced me to living theory.

Marit Hartviksen and Kjartan S. Kversøy are represented with their model SØT from the book *Samarbeid og konflikt - to sider av samme sak* (2008).

Nils Magnar Grendstad's book *Å lære er å oppdage* (1986) is a book about confluent pedagogy and inspired me to use pedagogical suns. He writes about confluent pedagogy which is based on the principle: to learn is to discover. And only you can discover for you. Confluent education is a teaching method, where the process of teaching and learning flows together. It is the aspect of integration of emotional, intellectual and psychomotor which is important. I thought this was close to my own way of thinking. Grendstad writes that confluent means: to bring together into one unit.

2.1 What is the nature of theory

I would like to make my claim to knowledge into a propositional theory. Then I could make a statement about how things are, because sometimes I'm pretty certain about how things are. My logic tends to be taking an “either-or” form. But the experience of working with people never take the form of either – or, but “both - and”. In many ways there are still difficulties with this term. *Rabbit said "Honey or condensed milk with your bread?" he (Pooh) was so excited that he said, "Both"*. (A. A. Milne 1926) It is still not accepted in everyday life with the concept “yes, please, I take both”. Johan Galtung (2006), the peace researcher writes that he, through his Peace Research has two close companions. It is “both-and” and “either-or”. In previous years this created unease in me when he uttered these words without a way to make a decision. Although I believe, as Galtung, that this is a point of view.

But working with people makes me see that I can't work in a propositional mode. People act differently in different situations and they feel different on different days, we are never the same, I'm never the same and that's why I think I'm dealing with living theory.

My experience suggests that my theory needs revisiting and reformation as the circumstances of my life change, so my theory is always in a state of living modification. However, I'm still a contradiction as you see from my first sentence. And I need to bear in mind that there is no "correct" form of either thinking or theory.

2.1.1 My ideas about theory

To me it sounds nice to be able to make a statement as a result of my research. Then I might feel that I have done "serious" research. If I had a statement, my research would have been finished and I could say "this is the way it is". But the principles of either-or, or with us or against us do not seem right for me. I keep on wondering why my students act this way or that way. I wonder: if I did this, what would happen then? And I can't stop wondering about how I can influence my own learning and thereby influence others.

When I supervise students on their tasks I tend to answer them with a question. Early in my own education as a teacher I read Plato (Imsen 2009) and liked the dialectic way of discourse he wrote about. Plato celebrated multiple ways of thinking, holding the one and the many together at the same time. In dialectic theory everything is open for a modification. My students, however, get irritated because they feel they need a straight forward answer.

The problem seems to be that everything you do contains a contradiction and that there is no theory which can explain the contradiction of living and oneself as a living contradiction. As I keep on wondering about a lot of things and also do that at my workplace as an educator, I find Whitehead's explanation of living theory good to me. "As we practice, we observe what we do and reflect on it". (Whitehead and McNiff 2006:32)

But I can't say I'm faithful to the one or the other theory, for it seems like I alternate between them in different contexts.

2.1.2 My ideas about knowledge

Knowledge is about what is known and how it becomes known. Knowledge can be understood as an empirical object of rational enquiry. Ryle in Habermas (1984, new edition 1997) explains these components as *know that* and *know how*. *Know that* is facts and figures. *Know how* refers to skills and competencies. Both prized for its commercial value. But if you

hold this view it's easy to look at things from a distance, a spectator's view, and analyze the parts. You can have this view according to knowledge as well. "The kinds of knowledge claims communicated by *know that* and *know how* are claims to objective knowledge". (Whitehead and McNiff 2006:33) Objective knowledge is generally held as the dominant form by the scientific community. I think when you work with people and try to improve yourself and facilitate for others to improve themselves this is not a good enough explanation on how knowledge occurs, when you work with people.

Reid (in Whitehead and McNiff 2006) challenges these by saying know *this*, without a direct object. He thinks that a subjective claim to knowledge is equally good. I agree on this view because I think it's a supplement to the discussion and gives a broader perspective on the discussions. The problem seems to be, it's easier to find empirical evidence on objective claims on knowledge. And the subjective claim on knowledge contains another kind of evidence and different validation processes. Habermas writes that knowledge can be criticized as unreliable. I understand Habermas (1984, new edition 1997) in the way that the close connection between rationality and knowledge says that what is rational in a statement relates to the reliability of the knowledge embodied in it.

When I read Donald Schön *The Reflective Practitioner* (1983) he writes that in some research you can do research within the set limits and that would be the right kind of research. These I think is *know that* and *know how*, and in some areas it's not easy with such an approach. Mainly his book is developing ideas about practice as a form of reflection in action on action. He also wrote, I believe directly too, about walking around in a swamp and looking for solutions other than the purely technical. I got lots of pictures inside my head about how difficult it is in the swampy lowlands. With big gnarled trees that can hide many things, reeds and water, mosquitoes, hot and humid. I felt that he was talking about my classroom life. Where I wander around, searching for solutions that are not easy to find because you are dealing with people and not technical solutions.

"(...) there is a high, hard ground where practitioners can make effective use of research-based theory and techniques, and there is swampy lowland where situations are confusing "messes" incapable of technical solutions". (Schön 1983:42)

He also says that in this swampy lowland you find the most interesting research approach and perhaps you need to choose where you want to do research. And we are some who choose the swampy lowland. I find myself in this swamp. Where I involve myself in messy, but for me crucial and important problems, and when describing my methods of inquiry, I speak from

experience, trial and error, intuition and muddling through. For this reason I see that the subjective claim of knowledge contains another kind of evidence and different validation processes.

Living theory is based on personal knowledge of *know this* and *know*. Because practitioners relate their work to their values, and draw on those values as the standards of judgment by which they evaluate their work. When you as a teacher are aware of your values and think that your teaching should be consistent with these and you evaluate your work according to the same standards, you draw on your personal knowledge and experience. “The values they hold at an ontological level emerge at an epistemological level as articulated epistemological standards”. (Whitehead and McNiff 2006)

2.1.3 My ideas about logic

This is about how I organize and shape my thinking. I can say I don't often use propositional forms of logic. Like propositional theory propositional logics tend to make statements about how things are, with no room for argument. Or I don't like to think about it if I do, because I see it as a closed way of thinking. Still I see myself talking to my kids in this way. “I say so, and that's the way it is”. Like Whitehead and McNiff (2006) write, and I agree that propositional logics tend to work in terms of closed modes of thinking, with everything in its designed place.

Of course dialectic logic works close together with dialectic theory. It works on the assumption that every statement is a response to a question. Collingwood (Collingwood in Whitehead and McNiff 2006) writes about rightness in question and not about truthfulness, because searching for truth can be difficult because it's about finding answers. Questions tend to be open and supportive, it creates an environment for creative spaces and they are in a dynamic relation to each other. It's more like this dialogue between my five year old daughter and me. I must warn the reader. This theme is typical for a five year old. When she's at the toilet she asks me “where does my poop go?” I ask her where she thinks it's going. “Into the ocean to the fish”. I ask her why she thinks that. “Because the fish has to eat”, she replies. “Do you really think the fish eat poop?” She answers “No, but the worm do and fish eat worms”. Oh, how so. “I found worm in the garden under the cat's poop”. And the conversation goes on and on.

And then maybe I find myself in a conversation of living logics containing the imagination of a five year old. She probably knows that no one eats poop, but it's fun to explore as if they did.

2.1.4 My ideas about forms of representation

Propositional theory can be written text on page, but more important is what the text says about theory. It is a set of statements that are non-contradictory and obey logic of inference. I hope I'm not claiming knowledge in my thesis as propositional. I will try to keep my mind open and not make a statement when I do my claim on knowledge. I claim that I know how it is to be a teacher who facilitates for changes in the social community.

I have been challenged to find my way to present my knowledge and my understanding of my living theory and I have to remember that my work needs to show that new learning emerges from previous learning, and any new learning already holds within itself its own potentials for improved learning. My form of representation will be living forms of theory told as narratives. It will therefore be linguistically represented. I do not use multimedia, even if I see that these media are the most adequate to represent a living theory.

2.2 Relationships between theory and practice

I started doing my action research project or what I liked to believe was an action research project. Today I can see I started out with an inductive method. I observed my class and its environment and I was fully aware of what happened and came to a conclusion that the environment wasn't good. I said to myself "if I do this what will happen then?". And then I did my first action. I didn't form a hypothesis and I didn't generate evidence of a statistical nature. I thereby didn't do hypothetic-deductive method. I'm now aware that I didn't fully understand the action research method, but I tried my very best.

My thought was that I should improve their environment, I didn't ask "How do I improve my practice?" or "How do I improve what I am doing to make a better environment?". Today I can see that the relationship between theory and practice didn't go together. I read the theory and did my work based on what I thought was good theory, but failed to make it my living practice. I also believed that if the environment changed it would be easier to deal with academics in my subject. Because that was a theme I needed to do something about, since my students weren't happy about the tasks we gave them. I can see that a lot of things changed, while I was working my way through the understanding of action research. And not at least

taking my values seriously, transfer them into my practice and let my students see them as well.

It's important for me to accept every side of action research because I see how my workplace, of different reasons, denies me my values. I make my workplace better for me and my students if I don't deny my values. And I see that the school system needs to be familiar with the deeper meaning of action research. For me it seems to be a good way of living.

I got in to a discussion about research today at my workplace. Some teachers really wanted to "take" me. I wasn't a researcher, I wasn't a professor, did I have a hypothesis and what kind of research is action research? Yes, I was allowed by them to say that I did observation, and that I used other methods, but it wasn't research. How on earth could I believe that I did research? I was just a teacher.....I cried later...for myself.

How can my practice and my experiences generate new theory? When I ask, "How do I improve my practice?" I claim there is a relation between theory and practice only by asking this question. Whitehead and McNiff (2006) support this when they write that practice can be grounds for the generation of new theory which in turn gives feedback into new practices.

2.3 My personal context

I am concerned because I see that students and teachers don't have a good time at school. I can't talk for all teachers but only for myself. I'm afraid that I wouldn't be able to work in such an unstable environment and call in for a long term sick certificate. The colleagues never talk about how we can improve our practice and that worries me as well. At the same time I was surprised that the students were so little independent and critical of what the teachers said and urged them to do. I wanted my students to say "what is the meaning of this?" "Why do we do that?", "Why are we learning this?" and "I'd rather learn more about this instead?"

In relation to the academics, tasks were so strictly framed that they gave little room for own thoughts in the development process. The tasks required long reports where they had to document their choices and at the same time reflect on their learning processes. It turned out to be difficult for students to work tightly with the tasks, and I felt they had little ownership of the tasks, and reflect on the learning process.

I have also put forward to my colleagues that we can actually talk with our students. We can ask students what they think about the tasks we give them. We should get the students more into the curriculum, writing the tasks together with them. Ask them what they think they

should learn and what they want to learn. We should create criteria for the tasks together, criteria that are attainable for all students. And in this way let them have the possibility to manage their own learning and school life themselves. For me this is pupil participation, empowerment.

Many teachers are afraid that the teacher loses control, that we lose focus and that we do not achieve the academic goals, but my experience this year suggests the opposite. Gordon (1979) writes exactly what I have been thinking myself. He writes about a teacher who wants to have a close and warm relationship with his students. He was afraid that the class would lose respect and that he would lose control of the class if this happened. I was told early in my profession that you should have a certain distance to your students. If you got too familiar with them you could lose control over the class. You could lose their respect. I experienced the opposite. This is also something my research will show in this thesis.

2.4 My locational context

I live in a small town in eastern Norway. The school I'm working at is an old Latin school and the culture in the school is influenced by it. I am one of the new teachers at school, but I'm not new to the profession. To me it seems that the majority of teachers are themselves trained from the old Latin school in the 1800's. And many of the comments and attitudes reflect this as well. I'm in for this crass idea, but do not want to offend anyone. We are all influenced by the education we have from early childhood and I am as well. It is in this culture I will do my action research. I know from experience that this is not the easiest academic community to engage in such "free flow" of research as one of the old lecturer called it. I will do my research with this culture in the walls and I will try to facilitate for my colleagues to get another view of how research can develop.

We are two teachers working together on the academic teaching, but I'm alone with the rest of the responsibility for the class, such as contact with parents, important messages, and so on. And I'm the one who is having all these "strange thoughts" about me and of the well being of my class.

2.5 My policy context

There are not many discussion groups in my workplace where we can have pedagogical discussions and we don't use experienced colleagues who can guide fresh teachers in how you deal with difficulties in the classroom. So I needed to develop my own theory while dealing with my students. We do have a set of school rules, this is an excerpt:

2.1 Læring-og arbeidsmiljø

Du er et medlem av et skolesamfunn som består av alle studenter og ansatte ved skolen. Vår skole forventer at alle elever bidrar til å skape et godt lærings- og arbeidsmiljø, slik at ingen blir utsatt for mobbing eller på noen måte kommer til skade.

It says that all students should contribute in creating a good learning and working environment so that no one is exposed to bullying or come to any harm. But how does school expect them to do so? It doesn't say anything about in which forum they can talk about this and how the teachers would be involved. Does this not exist in real life at school? Some students I asked about how they can create a learning environment say "we can be quieter in class, and then it would be a better learning environment". "We do not allow bullying in our class. If someone bullies our friends we give them trouble". When I ask them what is a good learning environment they say they really haven't thought about it.

There exists a policy at school, but we don't talk about it. And there can be a lot of reasons for that, but I feel that most teachers are interested in conducting classes without too many difficulties along the way. Then you can have your blinders on and avoid the difficult and unpleasant. This is a statement from me and not necessarily a truth for everybody.

St.melding⁹ nr. 30, Kultur for læring says "En betingelse for god læring er et læringsmiljø som inspirerer, motiverer og legger til rette for innsats". (2003:12) Moreover, they say "Læringsmiljøet omfatter blant annet det fysiske og det sosiale miljøet på skoler (...) elevenes muligheter for konsentrasjon og medvirkning, og relasjonene mellom lærere og elever". (2003:12) This report requires that a condition for good learning is a learning environment that inspires, motivates and facilitates efforts. The learning environment includes the physical and social environment of schools and should be able to give students opportunities for concentration and participation, and relationships between teachers and pupils. I feel that I

⁹ The Norwegian Parliament's report nr. 30 called Culture of learning (2003-2004)

have a good support in the school rules, laws and regulations. I see no reason why I can't use the students' lessons to work with class environment. I refuse to work with blinders on.

2.6 Values and context

I will briefly repeat my values and put them in context with my wishes. This is to show the tension in my research project.

I described my values as trust, fairness and honesty. I am an optimist and I believe in the good in people. I believe in listening and talking to people and to be a stable adult person in the class. When describing the attitude and the environment in this class I hope to facilitate for a change in me and for a change in the relationship with my students. I hope to facilitate for better circumstances for working with subject tasks.

Whitehead says we are a living contradiction. I didn't make this my living theory. I am a living contradiction because I have a set of values I deny myself in my practice. I didn't take the students or myself seriously. I am in a position to work with myself, my students and the environment. And my concerns show that I am genuinely interested in improving my practice. My dream for the class is that we can talk together, work with the goals in CC and write our own tasks - and all this in a nice, relaxing and secure environment.

2.7 Summary

I briefly mention some of my books of theory which I use in this thesis. I present my ideas of theory, knowledge, logic and representation. My theory and research are not statements but based on a principle of either-or. I present my research context and the relationship between theory and practice where practice can generate new theory. I write about how my ideas of values and context are combined because this provides the background for my research.

3 WHAT EXPERIENCES CAN I DESCRIBE TO SHOW WHY I AM CONCERNED?

I will start by telling a narrative from before my first action, I tell you of the first result and the possible significance of my learning. I show you my methodology, how I gather data and generate evidence. Then I will tell narratives from all of my actions, their results and how the changes evolved.

I use parts from SØT-model in the different actions. I use different tools and in action 5 I even try the tool “STOP” which I will explain later.

3.1 The situation initially

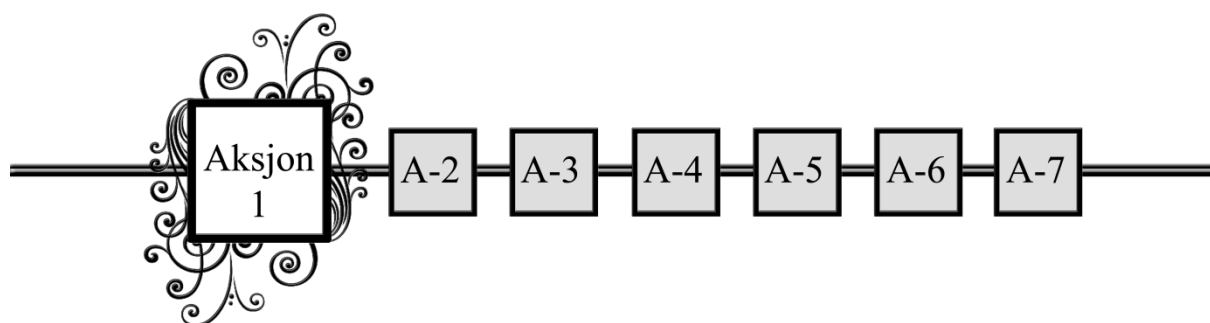

Earlier in my thesis I have painted a picture of a class with a very poor environment, with a teacher who did not think so highly about young people. At the same time I felt my previous dream of having my own home class. Class environment was not good and I felt uneasiness in me to work in this class with such an environment. I had one student who shouted me up in my face with the accusations that “You should never have been a teacher”, “You are incapable as a teacher” and “This must be reported to the principal”. I was upset and shouted back to the student. Other students said to me that I shouldn’t care about people acting this way. But some students started to get sick and had tummy ache on a regular basis. Daily students disappeared and new ones came along. It was an unstable student number in the class. I had to do something and that was a feeling which increased.

I would try to talk to them and convey what I felt during these weeks we had been together. On impulse, I asked the students to sit in a circle. This principle is often used in guidance and is also often used in primary school in conflict solving. The theory is that in a conflict we feel

the conflict so strongly that we ought to know that the others are feeling the same way. When using this principle you facilitate that the individuals get credit for their thoughts and feelings and through the dialogue they also feel the community. We use words to make a common understanding of the situation. Gadamer writes about understanding in his book *Truth and Method* (2010) that understanding is to meet the foreign with wonder and openness. If we don't achieve such a wondering it is an obstacle to understanding.

My students felt a bit scared without the desks they were so used to stay behind, so to protect themselves they moved the desks in a circle. I thought that was ok because this action came sudden upon them. I presented myself. According to Grendstad (1986) it is important how you present yourself in a conversation. He believes that one must acknowledge everyone's own feelings and not draw conclusions from what we observe; posture and emotions. I must say how I feel in this situation and what I feel now. And again, try to catch up if students are interested in communicating some of their feelings about the situation to me. This is also consistent with Hartviksen's SØT-model. In a conflict, it is important to say something about how you are doing in the situation now. This is the S-situation now. Ø- your situation of wishes/desire, T- measures that can build a bridge over the situation now and the desired situation.

3.2 Results of my first action

When one of the students shouted at me I got a lot of support from my other students. They also said they supported anything I would say to the principal to get rid of this flamboyant co student. I said that this is not possible and we should try to find another way for this student to achieve her education. My principal understood me and gave me support. I also told him that I needed to work with the class environment. He did understand that I was in a difficult environment, but he was also concerned about the academic. Did the students learn anything and did I take time from the professional? I tried to explain to him, but I felt it was difficult to defend what I wanted to do, because there is no culture in our school working with the class environment. As I have said earlier, most teachers are very concerned with the academic. I also said earlier that there is no culture for talking about this phenomenon at our school.

I did my first action as described in chap. 3.1. All my students were talking once at a time. They told each other how insecure they felt in this environment, they didn't want shouting and yelling, some of them wanted to switch to another educational program at school. They thought this program had too high standards for students and that the teachers were not

pleasant. I asked if I could respond to the critic. And I said to them that the standard would be kept as high as it is and that if this program wasn't for you, you should decide quickly if you wanted to quit. (This had to do with rules for how you should quit school and still have a place at school for next year). But we could do our tasks in a different way. And about me, being a teacher I certainly could change my behavior. They said I was grumpy, quick to dismiss them and unwilling to listen to them. I can confirm this and that makes it pretty valid. I can therefore claim my first knowledge. This environment didn't make me the good teacher I could be.

To make this valid data I wanted to talk to my colleague, with whom I share my class. I was excited and proud when I told him how open the students had been, and about feedback to me as a teacher. I was surprised when he dismissed me and made a statement which I perceived as patronizing both for me as a teacher and to the students. I would say that I know him a bit better today, and sometimes he can come forward as a little abrupt.

“If students don't want to be here, let them quit. We don't need them, they need us”. “If they don't want to do as we tell them to do, they can quit”. “Do you really think this is going to help our students?”. I'll be honest; it pulled the rug from under my feet when I got this feedback.

I can say I experienced something, and possibly drew a conclusion out of these events. It told me it's difficult to work alone in an environment without a culture for talking about anything except subject. It also told me that I should have been smarter and told my colleagues in advance what I wanted to do. Dewey (1927) writes that if you become challenged on old habits it is scary, and the only thing you can do is to keep the door ajar, to try to be a little open-minded.

With students in mind, I took action, because I felt an urge to do so because of the ongoing bad environment. I also improved my own practice when I started to listen to my students. I also took seriously what they said about me, and wanted to change my attitude at school dealing with my students. I wanted to take time to listen and talk to my students. We made a common understanding of how we are, and the result can be more tolerance and patience for each other. I have read Grendstad who writes that confluent pedagogic emphasizes that students should learn to know their feelings. We do this because we recognize that emotions have a major impact on the pedagogic, the personal, interpersonal and societal level. One can learn to exploit the feelings of a positive resource. The feelings shouldn't dominate, but find its balance in relation to, and integrated into, the other processes in teaching and learning.

“Følelsene skal ikke dominere, men finne sin balanse i forhold til, og integreres i, de øvrige prosesser i undervisning og læring”. (Grendstad 1986:64) Emotions are subjective and only I can feel what I feel. Sometimes we have feelings that are difficult to understand for others. When I recognize that you have these feelings even if I can't understand them, they are yours exclusively, I have a phenomenological understanding. When I use a phenomenological log I get exclusive access to what students feel and think. At the same time Grendstad writes that feelings talk through the body, what we call body language. But we must be careful to say that we know something about the other person even if we can “read” his body language. We can say something about it, but we can't know for sure. We can call it and present it as guesswork. We must remember, to be certain you have to ask. Each person talks for him or herself.

3.2.1 Summary results

I can say that the result of this action was that some of the students actually decided to change program at school. They say today that “it was for the better for me”. “I took it seriously what you said and decided that this program wasn't for me”. Some of the students quit in some subjects and then there were just 14 students left.

In the relation to the psychosocial environment I could see changes like the fact that it was quieter in the classroom. It appears that the students calmed down and relaxed more. They also showed interest in becoming better acquainted with each other. Other teachers commented this like “it's easier to be teaching in your class now” and “it's calmer in your class now”.

3.2.2 Claim on knowledge and significance of learning

I'm focusing on myself to find episodes where I think that my new learning has influenced the learning of others (my students). My reflection on this action is that it seems to make the environment calmer when I listen and talk to my students. When I'm honest about my feelings and let them talk about what they feel. I claim that if you show your honesty you can talk with students even if they don't know you. It is safer when you have a relationship with the students, but if you don't take the risk you wouldn't know.

The significance of the learning is that it's important for students and teacher to be honest, to talk and listen to each other. It seems that as a student, person or human it is important to be seen, it creates trust between student and teacher when the teacher has such an approach

towards students. This shows that recognition is important in a lot of situations, especially when it's about creating trust.

Today when I look back I can see it was a good thing that it wasn't a much planned action. When it was improvised from the need to improve my practice I felt that I became a closer part of the action. The danger of good planning is that you can get into a position where you do research on and not with the students.

3.4 Summary

I started this chapter by telling you a story about a class with poor environment and with a teacher with a bad attitude. I showed you the results of the first action which involved some quitting students and a change in my praxis. The change in my praxis is because I started to talk to my students, which is new to me and us. I also claimed my first knowledge and significance of learning. It's important for both parts to be honest, to talk with each other, and you create trust when you see and take your students seriously.

4 WHAT KIND OF DATA WILL I GATHER TO SHOW THE SITUATION AS IT UNFOLDS?

The purpose of gathering data is to generate evidence to support and test a claim to knowledge. My understanding of data is what I have stored such as reflection notes, computer files and my written observations to show how the action unfolds. It is important to gather data from the start that can give me quality evidence. I have reflection notes from myself and my students after the actions we did. I call the reflection notes log.

Whitehead and McNiff (2006) ask an important question “Evidence of what? My “what” should be what I am studying to support my research questions. “Episodes of practice to show how I have developed my learning and episodes where I think my new learning has influenced the learning of others”. (Whitehead and McNiff 2006:64) They follow up this by saying if you don’t have the right focus you may not maintain your research as action research, but slip into social science research.

4.1 Which data and who gathers them?

Today when I look back, I can say that I didn’t fully understand the action research method but I was so eager to get out there and do action research. I just wanted to do things better for my students and myself because we all struggled with the environment. As Dreyfus and Dreyfus (1986) write I went from being a novice to an advanced beginner through acquiring new knowledge and experience through mastering real situations.

I want to gather data which make a good narrative inquiry about year 2008/2009, about students’ and teachers’ environment and about the changes in the class. I want to show how the story is unfolding and try to catch situations which can gather data. I have gathered data through log, which my students wrote and they show what my students say, mean and want at that time. I realize that next time I want to do changes in the log, like asking different questions, because I know the action research method better. And I used a qualitative survey. I talk about this in my methodology chapter 1.4.3

I have monitored my students’ learning and action. I can comment on their actions but only they can comment on the learning that enters into their actions through the exercise of their critical judgment. Next time I will monitor how they respond to me through multimedia. Do I respond to them with respect? Do I talk respectfully to them? Do I listen or do I pretend to listen? When you use multimedia forms it is easy to monitor these questions.

To be an action researcher next time I will ask questions like this: “what am I doing in relation to others?” but this time I was thinking, ”how can I gather evidence of what they are doing and saying?”, “what are they learning from what I am doing in the lessons with different themes?” By asking this kind of questions I made the questions my road to discovery.

4.2 Focusing on me

Whitehead and McNiff (2006) write that you gather data to generate evidence and you can do this by focusing on yourself and others. When I am focusing on me I will gather data and look for practice that shows how I have developed my own learning and episodes where I think my new learning has influenced the learning of others.

To find out if you enhance your learning “in here” and how this affects your action you can observe and monitor what I do “out there”. I need to have focus on what I do and not on what others do. You can ask your participants or your validity group to monitor you in action. Then you can ask them to look for something special, but then you have to explain what they should look for in order to your standards of judgment.

When I monitor my learning and my actions it involves several things and I have designed some questions which I think is a good way of monitoring myself and I will try to answer them in relation to my first action.

1. Did I record what I did? Yes, I wrote action plans which contained the situation initially, plan action, doing action, reflection and changes. I chose to do this in a written form.

2. Did I reflect on what I learned from what I did? Yes, I reflected over my actions and what I have learned. This is an extract from my first reflection: *It seems to make the environment calmer when I listen and talk with my students.* My students also said I was grumpy. I have in my reflection recorded that I listened to them and said that “I certainly could change my behavior”. This shows me that I did reflect on what I did and I reflected on the feedback my students gave me as well. I learned that it’s good for both parts to talk together.

3. Did I enhance my learning “in here”? Yes, I did. When I reflected on my learning, I talked about it in a validity group. I talked to my colleagues and got feedback from them. When you reflect on your learning, you enhance it. When I start to enhance my learning in here I affect everybody around me.

4. Did it influence my action and what I did “out there”? Yes, it did. I started creating my own living theory. By listening and talking more, using more communication, it affected what I did out there. I facilitated for both students and teacher to improve their practice.

5. Do I have some possible significance? Yes, I have. I can claim on the background of my student’s log and my own reflection notes. It’s important to recognize your own feelings and put words to them. It creates an environment where you can build on interpersonal relationships.

When I monitor my learning and action I can find out if my research realizes my values. I can by saying something about my standards of judgment establish validity of my theory. Then I can claim that I have improved my practice. And I can also claim that I influenced my own and others’ learning.

4.3 Focusing on others

I need to have focus on me, but I also need to check out how I have influenced my students’ learning. I think it’s important to have focus on both, especially in my class where both teacher and students have problems with their interpersonal relationships that affect the environment. To check how I have influenced my students’ learning I have to monitor the respond they give on me. And they do. When I ask questions in the log as “What did you feel...?” They answer like this: *I feel it’s good that Grande (the teacher) wants to discuss things and cares for what we want and in which way we learn best.*

This quotation shows that I start to enter their thinking and how they have begun to mediate my influence by incorporating my ideas into their own thinking in their own original way and through the exercise of their critical judgment.

Monitoring others’ learning and actions involves that my research participants need to maintain their reflective journal. I used log after each action and they did reflections there. I realize that next time they could have done it in a different way like using cartoon strips, video and other creative ways of monitoring their reflections on their learning. We could also have started an e-blog which is a way of making our processes public.

While monitoring their actions it would have been fun to use video. It’s a bit awkward in the start, but then it’s really informative. We used log after each lesson we had an action and this worked well.

4.4 How are data gathered?

My students wrote log after each action, the themes they wrote log about is chosen from the situation the class was in. I planned the action, but I didn't know what kind of responses I would get from my students. And I didn't even know if my action would work the way I wanted it to. This I understand is an action research reality.

I found themes for these lessons depending on how the situation in class unfolded, and the situation could occur randomly. When I say I wanted my action to "work the way I wanted" I mean, that I had wishes for my class that it would be a calm and stable learning environment. But I had no control over what the results of my actions could be. I could not predict that, and that feeling made me feel that I had little control over the situation until I learned to be a dialogue partner and not an oracle. T. Gordon (1979) writes that the teacher feel he needs to be an oracle. He needs to know the answer of every question and predict the outcome of every situation.

It's also important that data is gathered through the whole period we did actions. In this way you can aim to show the developments through the time period we did actions. This is a log from my students in the first action and the last action I did:

My first action:

1. What did you feel? *I feel proud that I know the class so well.*
2. What did you discover? *I discovered that the students are interested in learning which I didn't believe.*
3. What did you experience? *I experienced understanding in what my class is thinking.*

My last action:

1. What did you feel? *I feel it's nice with a good dialogue in the class and it's nice to share our meanings.*
2. What did you discover? *I discovered that I can affect my learning through student participation.*
3. What did you experience? *I experienced that it is constructive for our learning environment that we can discuss the problems in the class.*

This shows developments in using the language, the words to describe what they are thinking. They put words to their thoughts, feelings and experience. They share meanings and use

dialogue when they have problems, and they realize that they have the power to change their everyday school life. And I think it's wonderful.

I gathered data as log from my students, but my questions in the log were not the same each time. I changed them because I saw that my students didn't answer all of them. The questions were too similar to each other. And I developed as well and got a need to change the log so they could increase more knowledge about what I wanted to know.

4.5 Summary

What kind of data will I gather to show the situation as it unfolds? In this chapter I have explained which data I need to gather to produce a good narrative story and to support my claims when I say I improve my practice and others' practice. I say something about focusing on myself and my students and how we monitor our learning and actions. I also give an example of how my students develop through the year of action research.

5 HOW DO I EXPLAIN MY EDUCATIONAL INFLUENCE IN LEARNING?

This is about understanding the processes of generating evidence and how we articulate appropriate standards of judgments so we can turn data into evidence. When we got evidence we can use them to support our claims to knowledge. I claim that I have influenced the quality of learning for myself and others.

5.1 Sorting and categorizing the data

At this point I have a lot of data. Now I need to sort and categorize it. How do I do that? I did my actions in order of a date and sort my actions and data after this. In the start it was a while between my actions, but in 2009 I started to do them on a regular basis. I realize that I got different kind of data depending of which kind of question I ask. My research question involves improving my practice and my students practice. Then I need to ask questions that show how improving are taken place and how it enters into action.

Which kind of standard do I want to use to categorizing the data?

5.2 Analyze the data for meaning

I gather data through collecting logs from my students and when I wanted to transform my data into evidence I read my logs and mark what I find interesting with a pen. I let three other people do the same and we found a lot of interesting things in the logs, a lot of the same thing I must say. When four brain “wash” data like this, something will come at sight.

When I got data as log its qualitative orientated data and it isn't easy to categorize. I need to look at both, parts and the whole. In this way I can try to get an overall impression of the material I have gathered. I think my logs describe very well the situations in the actions and then I can pick out quotes that describe the main impression. It is important to have a realistic view on your data like Dalland writes “Et realistisk syn på verdien av egne data er en forutsetning for å trekke riktige konklusjoner”. (Dalland 1997:92) And Whitehead and McNiff (2006) ask if you find data you don't like what do you do then? I write more about that in 5.3. When reading your data you already got your categories, but you haven't articulated them in terms of standards of judgment.

5.3 Identifying criteria and standards of judgment

Criteria and standards of judgment is not the same thing. I think that educational goals in The CC¹⁰ are criteria we just can check out of a checklist and it doesn't say anything about how good my practice is or what the students have learned after a lesson. I need to look for different things to show what is good or valuable in the different situations in my actions. I can look for a practice to be valued or a quality to be valued in my actions together with my participants. Or I can find other things to value, but I need to articulate them. I can even find data that show things as I don't want them to be. What will I do then, and how can I use such kind of data? I got students who answer questions in the log like this: *I think there are some ignorant people in this class.* After a year working with the environment, sometimes they still feel badly about each other. I think it's too much to demand that everybody would like each other. We can, as I wrote earlier, have an understanding of each other and accept each other anyway.

I think this is boring. I didn't discover a thing because I don't care about this. There will always be someone which doesn't involve themselves for different reasons. It doesn't mean that they are unaffected by what happens. I choose to believe that they can't take on the changes that occur. Everybody knows that it can be a bit scary with changes.

I talk to them I want to talk to, the others I don't care about. You can't force people to like everybody and we are created differently. As long as you are polite and not rude there is no need to speak with everybody. This has to do with respect and my class is very concerned about respect which you will see later.

Whitehead and McNiff (2006) say that we use different standards of judgment as ontological, epistemological, methodological and pedagogical. We take action to improve a situation and we move in the direction of what is good. In this way we identify our standards of judgment based on what we consider is good. Some of my grounded values are trust, fairness and honesty, but when I generate evidence I will have those values with me, but using standards that are more recognizable in our daily life in the class such as:

Reflection, democracy, safety, respect, good social relationships and to learn is to discover.

¹⁰ The Royal Ministry of Education, Research and Church affairs -The Core Curriculum¹⁰ for primary, secondary and adult education in Norway contains for my subject 34 different educational goals.

Do I find data in my action that show learning taking place? Do I find data that confirm that my students making their own decisions about what they want to learn?

Yes, I do. In different logs my students say *I feel that this challenge showed me how it's easier to feel secure and happy*. This shows me when I facilitate that they are seen, heard and taken serious they have confidence in that we can improve our environment. The trust between the teacher and student will increase when the environment changes. I also say that with a quotation from another log. *I feel tired, not concentrated and hungry*. I have used their lunch break to work with these themes and even if they are both hungry and tired they answer the logs and they also say that: *I experienced insight into that the class was thinking alike*. These quotations show that they are honest when they answer the log. It shows they are honest in their feelings and about how they are, and that I can rely on what they answer as the truth.

5.4 My standards of judgment

I want to find standards of judgment to show that my practice is good as in educational good. I will as Whitehead and McNiff (2006) writes use standards of judgment to try to establish how I facilitated for the educational influence in learning. When I started this project I didn't even think about ontology, epistemology, values and embodied knowledge. These concepts have been introduced for me through my reading of different theory, through dialogs in the valid group at Hiak and through reading Whitehead and McNiff (2006).

I have an understanding on how I see this world and this color how I act and interact with other people. I think we are one of a kind and that we need to have interpersonal relationships to feel good. I think as Husserl (Husserl in Whitehead and McNiff 2006) that people have capacity to turn their embodied knowledge into their living educational theory. When I prepared for my students to improve their practice through articulate their own values in learning, I hope to supervise them to increase their own living theory.

What is my object of enquiry? It is about me, my class, our environment, pedagogically and academic content. It's about setting a standard of judgment which is to do with creation and testing educational theories, and how my unit of appraisal in my claims to knowledge.

I used my educational values as assessment of my own educational standards. So what are my educational values and how can I use those assessments of educational standards? I know that I like the idea on the Grendstad (1986) said "to learn is to discover for you". And that only you can discover for you. Although I believe there is little time available in schools to let

students explore on their own. I also believe in being a facilitator, a supervisor in learning processes.

When I define my educational values, I make the starting point for my own educational standards, which is a standard for my execution of pedagogy in the classroom. It is when I carry those values and standards that I develop my own living theory.

5.5 Significance of my learning

The importance of learning after doing action research and writing an action research report and everything else I learned along the way are important for the development of educational action research and theory. When we set our criteria based on our values and how we live them, they are our living theory. Our living theory is evolving all the time because we are alive and in constant development. These standards of criteria we use as good reasons for what we believe is valuable and well both when setting the quality of our relationships and our work.

With these standards of judgment in my head I can say something about my educational influence in learning.

How can I say I have educational influence in learning? I think it's about saying something about influencing whom. I have influenced myself, my students, a very good friend who also do a master program, some of my colleagues and hopefully later they who chose to read my thesis.

I influenced my very good friend through discussing, arguing and talking about different concept and understanding of the different concept. And not at least talking about how we facilitate to improve our practice and how we evaluate the practice as good. When we talked together we created a common understanding of a lot of these concepts' we use in our action research project. By doing this you also make your research valid. Of course this influence doesn't go only one way, we influenced each other.

I have influenced my students in such a way that they start to use pedagogical suns when they have exam. One of my students delivered an exam with a big pedagogical sun. She told me that she used it as a kind of mind map. These too things were coherent for her. They also use the educational goals from CC different from before when they are writing their own tasks.

This is what my student said after the last task I gave them fall 2010:

One of my colleagues which has another class at my school wanted to use the concept of pedagogical logs working with her class environment. I advised her to use logs as well with phenomenological questions/focus. Only when you ask them who are involved, you can have the exact answer and view over the situation and how they actually feel. We were talking about what kind of question she should use, why these kinds of questions are good and how she can use the log afterwards.

My learning has increased in many ways and on different levels on the personal and professional level. First I recognize that I understand action research method better. I don't fully understand, but I am getting there. Then I see that I've started to use my values in my teaching and then I realize I got my living theory.

I also use listening and dialog more often. I thereby talk with and listen more to my students. I also listen more to my colleagues as well. This seems too facilitated for them to talk and ask more about what I have been doing with my students. I think I am more humble now when I realize that my truth isn't the only and right truth but I still lecture about that we create a better environment when students and teacher feel close to each other and that we need to facilitate relationships before the subject.

5.6 Summary

How did I explain my educational influence in learning?

I explain my influence on learning in that I have changed my way through this action research project. I have therefore been facilitating for influence my students' learning by making students aware of what they are entitled through Læringsplakaten. Students say they find that they are entitled to student participations among others in relation to the school. They discover they have the power to influence their own school weekday and that they have influence over their own education. And their voice is heard.

Once I identify the standards of criteria on my work through these actions and what students respond in their logs I have influenced both mine and others education.

I claim that when I share my responsibility for the content of teaching, learning processes and methods I facilitated for my students to take this responsibility themselves.

6 HOW DO I SHOW THAT ANY CONCLUSIONS I COME TO IS REASONABLY FAIR AND ACCURATE?

Validity and legitimacy are related issues. Validity is about showing that the results of my research are trustworthy and establishing credibility in my claim to knowledge. There are several ways to validity a project. Internal and external validity are common terms when it comes to doing this.

Legitimacy is about the reliability of the project. It is about establishing the authority of the person who makes the claim to knowledge. (Whitehead and McNiff 2006)

6.1 Establishing validity and legitimacy

The validity is about establishing credibility with in my claim to knowledge. My claim is that I have improved my practice and facilitated for my students to improve their practice. Validity is therefore did I improve what I say I have, that I know how and why I have done so. You also use some standards to say something about the reasonableness of the claim

It's also about establishing authority of the scholarship that leads to the claim. The practitioners who make such a claim from their practice make automatically validity in their scholarship and in their authority as a practitioner researcher. When a knowledge claim demonstrated its validity it transformed into a truth claim. (McNiff and Whitehead 2009)

How do I do this? I think when I use my students log to claim knowledge and show significance of learning I establish a valid evidence base. When I get confirming from my students that the action is recognizable I think that my evidence base is valid. This is about triangulation of evidence. In one of my actions I brought the story from the action back to my students. I read it for them and they recognize what was said and done in the action. They made my evidence valid.

I lean on Whitehead and McNiff (2006) when they say to establish legitimacy you need to get other people to accept the validity of your claim, but it often have to do with power than rationality. I described a situation in chapter 2.2 involving my colleagues in a discussion about action research. It wasn't a constructive discussion. It was uncomfortable to be put in that situation because I felt I didn't have any authority in my claims. In this situation I did feel pretty powerless and vulnerably and not in any position to claim anything. How to deal with such situations is not easy. I thought it was very uncomfortable and prefer therefore to work in silence to convey my claims.

6.2 Power-constituted contexts

When I refer to the situation above I didn't get a chance to answer for myself. They didn't articulate their reasons or showed me why their opinion is more justified than mine. I felt it very unfair and I wonder what give them the authority to make such statement. "They can be seen as violating the condition of democratic evaluation". (Whitehead and McNiff 2006:100)

When working alone in such circumstances it is easy to feel tiny and little seen. I say that to be seen and recognized is important for my students, but I think it's important for everyone, even an action researcher. Later I experienced close colleagues who asked for advice for what to do with her class. Since my experience is that not everybody acts negatively in my existing context I will work with my closest colleagues and maybe present my thoughts and research to someone in management who believe in the same as me. Maybe it's being a coward, but I don't have the guts to resist such pressure.

6.3 Social validity

In action research teacher and students cooperate in democratic processes to improve our practice. Action research has to do with democratic evaluation and I lean on Greenwood and Levin who writes "Action research aims to solve pertinent in a given context through a democratic inquiry where professional researchers collaborate with participants in the effort to seek and enact solutions to problems of majors' importance to local people. (Greenwood and Levin 1998:75) To be in a democratic process like this, both parts need to agree about some criteria for establishing validity and legitimacy for the research.

Whitehead and McNiff (2006) writes that Habermas (1987) writes that to reproduce an existing social order we need certain rules to maintain the normative judgment. And they use Habermas to create social validity and intersubjective agreement. I have read Habermas *What is universal Pragmatics?* (1976) and as I understand Habermas it is more about creating a validity basis of speech. If we want to be acting communicatively and to participate in a process of reaching understanding we need to raise validity claims. Kversøy and Hartviksen (2008) use a different word "samsnalking", which mean talking together over time to create a background that everybody has an opportunity to understand. The purpose is to show what we mean with the words we use instead of assuming what they mean with the words they use. The purpose is the same. Habermas criteria is about communication, whether it's to create a normative background or not.

I choose to use Habermas's terms and I write short write more about how I understands Habermas: He says that to participate in a process of reaching understanding you need to raise validity claims. I like Habermas, claim to be:

Uttering something intelligibly.

Giving (the hearer) something to understand.

Making herself thereby understandable, and coming to an understanding with another person.

Habermas say further on:

The speaker must choose an intelligible expression so that speaker and hearer can comprehend one another. The speaker must have the intention of communicating a true proposition (...) so that the hearer can share the knowledge of the speaker. The speaker must want to express her intentions truthfully so that the hearer can believe the utterance of the speaker credible (can trust her). Finally, the speaker must choose an utterance that is right with respect to prevailing norms and values so that the hearer can accept the utterance, and both speaker and hearer can, in the utterance, thereby agree with one another with respect to a recognized normative background. Moreover, communicative action can continue undisturbed only as long as all participants suppose that the validity claims they reciprocally raise are raised justifiably. (Habermas 1976:22-23)

If I understand Habermas correctly he believes that you need to express yourself so it is comprehensible to others. You must communicate the statements in a truthful and sincere way so what you say will be perceived as true and it must fit into the context, be appropriate to the normative background.

6.4 Personal and social validation

In my personal validation I need for a starter to believe in my evidence-base, in my claims and my research. I've used my critical sense and reflection to validate that I believe in my research. I need to have courage and confidence when I talk about my research so that the others would believe in me. If I don't have this how can I claim with conviction and make others believe in me?

Social validation takes form as meetings with my validity group at HIAK were the group is critiquing my work in a respectful way. They have feedback which you haven't thought about and we could discuss different problems, themes and concepts. We meet at a regular basis and they can monitor the progress in my thesis. I think this is a good way of validation and it

purpose is to see if the task contains what it says it should do and give me accept for working on the next step. These meetings are “(...) conducted in the spirit of democratic evaluation”. (Whitehead and McNiff 2006: 105) this means that they who is about to judge the thesis needs to do that after the same standard as the person who wrote the thesis. If I use Habermas’ criteria which is to be truthful, sincere, appropriate for the context and comprehensible I put the foundation for my critical friends and validation group, or perhaps people at my workplace, to show that my narratives and claims of knowledge is evidence and just not illustrations. My judges’ responsibility is the same. Both parts need to agree about these standards of criteria. I can see myself in the situation described earlier, were I stop my “judges” and say to them: “If you want to make my research valid and believable you need to use the same criteria as I do, which is Habermas’ criteria”.

6.5 My way and Habermas’s

The way I understand the process of validity and legitimacy it is reasonable that the evidence base is valid. When we establish standards for judgment in both personal and social basis, it is important to have the same criteria. I want to use Habermas’s criteria, they can also be used not only in the process of validity. How can I through these criteria show that my conclusion is fair and accurate?

Comprehensible – I use a plain language, I explain words and expressions, I use quotations right. I secured that others understands what I mean by asking them. I have reasons and justifications for doing my actions. This is from my planning in the second action: *I felt that my students didn’t feel secure at school. I want to take their feelings seriously and let them discover that there are a reason for why they are in this student program”*.

Truthful – I tell and write what I mean with sincerity and involvement, so that they who listen and read can share my claim to knowledge. I have tested my validity of evidence against critical feedback of my validity group. I have also taken critic from my students: *I don’t want you to join us as friends because I got enough friends...I have no benefit from what you do for I talk to those I want to and those I don’t want to talk to, I don’t talk to.*

Sincere – This I do in an honest and wholehearted way. I have acted sincerely in the way of wanting my students the very best and that *we have the best time ever at school*, as some of my students express themselves.

Appropriate – It is appropriate in our cultural, normative background. In relation to HIAK, were I do my master program were it is a formal established an action research environment. But not at my workplace, which don't content such an environment.

This brings me back to my workplace and my closest colleagues. I realize that I have talked to my colleagues through these years of action research about what to do and not to do.

Sometimes they said what I was doing was difficult to understand, and that they don't want to do such test on the students. Even if I went through with it and they said "I told you so", I didn't quit. I was forced to go on because I wanted to improve my way of doing education and I want to facilitate for my students to improve their school everyday life.

My recent experience is that I where asked for advice to help someone else to change their lousy class environment. I was delighted, thinking that it is good that I held out and when you spread the messages it is like tings in the water.

In the start of this chapter I say this: *My claim is that I have improved my practice and facilitated for my students to improve their practice. Validity is therefore did I improve what I say I have, that I know how and why I have done so.* I didn't answer these questions here because I want to show you my actions which tell about enormous changes.

6.7 Summary

In this chapter I have established validity and legitimacy about my claims of knowledge. I have shown my personal and social validity, and that it isn't easy in a power-constituted context to claim knowledge and that both parts need a standard to judge the claim. I have show Habermas's criteria for social validity for judging my evidence.

7 WHAT COULD I DO AND WHAT DID I DO? PART I

I have done two kinds of actions. Or actions in two different areas to improve my environment and to improve how I work with my subject. I will not go further in to what kind of subject I teach, because I keep my student anonymous that way. My actions go from fall 2008 to late fall 2009.

I have decided to split my actions in two parts. One part (Part I) is about the environment and the other part (Part II) is about the tasks, but in reality, I work with these parts together in praxis.

I described my first action about my environment quite detailed and maybe more like a narrative story. Now I will describe what I did, what results I got, significance of learning and claim on knowledge in my other actions (Part I) when I work with environment. Then I will do the same with actions considered the subject (Part II). Planning, what did I do, reflection, students log, significance of learning, my claim of knowledge and changes are headlines I followed in these actions.

7.1 My second action- three pedagogical suns

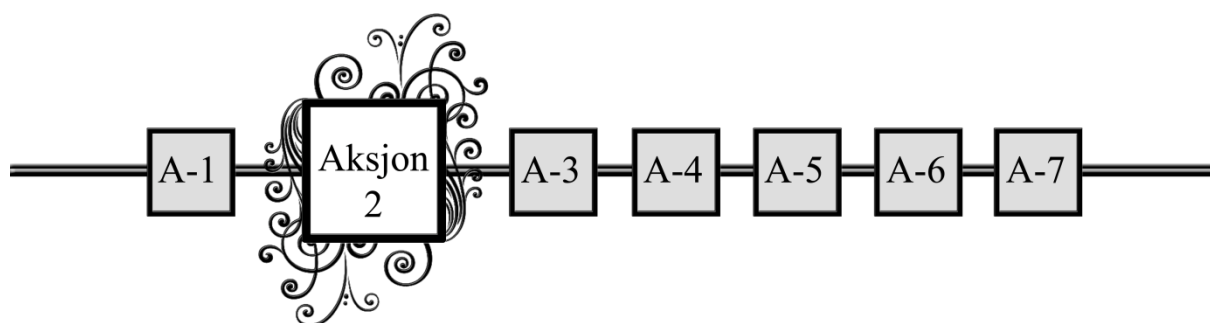

I'm still focusing on the environment because I felt that my students didn't feel secure at school. I worked with three pedagogical suns with unfinished sentences inside. Grendstad (2006) says that an unfinished sentence creates a desire in us to finish the sentences. It would be easier to get answers to many problems by making an incomplete sentence that must be filled out than to ask a question. "Dette forhold innebærer at det ofte vil være lettere å få svar på mange problem ved å lage en ufullført setning som skal fylles ut enn å stille et spørsmål". (Grendstad 1986:176)

Grendstad means that the teacher will get fairly good understanding of the individual's understanding of the word if he is allowed to read what is written. My three suns were:

I started on this program because...

I learn when.....

I thrive when.....

7.1.1 My planning

I want to take their feelings seriously, I want to let them discover themselves that there is a reason for all of them why they are in this student program, and that everyone knows when they learn best, they just haven't thought of it before. I prepare a log which I believe is appropriate for this action. It contains three questions. What did I discover now? What did I experience? What did I feel now?

I clarified with them that I'm working on a master program and that I would like to do an action research project together with them. I would give them a piece of paper to write on. I shall draw the sun on the blackboard and make the sentence unfinished inside.

1. sun: I thrive when
2. sun: I started on this program because ...

I will go through what students wrote on the piece of paper and talk about what they wrote. Students should write log afterwards. I will embrace what comes to my face. With that I mean you could never know what is happening when you push different buttons in people. You can actually start some feelings you need to deal with. And I should be aware of the ongoing environment in the class, with that I mean it's still unstable.

7.1.2 What did I do

I presented that I was doing a master program and asked them if I could try out a few things in class during the year. There was no problem. I handed out pieces of paper to them and said they should draw a sun like the one I drew on the blackboard. They should complete the rays of the sun and submit the sentences and it should be anonymous. After the first sun, I read the answers and the students were very attentive and interested. After the second sun, I wrote the result down on the board. The students lost focus and started doing other things. I decided to do a third sun, because it seemed that I lost my students focus. My thought was that I lost their focus because I turned my back at them when I wrote at the board. To get their attention again

I decided to do a third sun. Then they were in focus again and I think they like to get attention from a teacher.

3. sun: I'm learning when

After the third sun, I read the results loud and again I caught their attention. I choose to reproduce some of the response on the suns: It is different logs from different students.

1.sun: I thrive when *all are friends...we can work together...when I don't worry...when I feel secure at school...when teachers are gentle...when the teacher give me credit.*

This shows me that they thrive when they feel secure at school, when there is a positive environment and when they get positive feedback from the teacher. In other words, it's about a secure and stable class environment.

2.sun: I started on this program because ... *I want to be creative...I like to draw, art is fun...wish me a final paper of my skills...I will develop my skills...I will achieve my dream.*

This showed the class that many of them had common interests and that they want to learn and develop themselves. They are more similar than they thought.

3.sun: I'm learning when ... *I do not talk too much...when teachers have time to help me...I concentrate...the teachers are enthusiastic...I can work independently...it is quiet in class.*

I mean that this is a duality. By this I mean that if they are quiet and focused and the teacher is active against the student, students actually say they learn. They discover already their learning strategy, but haven't words to the concept yet and they told me.

I took a chance when I did the last sun because I felt it was one too many. But it went well. Afterwards they wrote a log. What did I discover now? What did I experience? What did I feel now? I wanted them to write their name on the log. I will say something about this in my reflection later.

7.1.3 My reflection:

I discovered that students listened to me and it seemed that they thought this was exiting. I felt that the students calmed down and they got a greater understanding of each other. Some of my students say in their log: *I'm feeling a little proud because I feel that I know my class well.... And that I actually thrive.*

The immediate reaction was that they worked more concentrated and was quieter when I started with my subject. Other students say: *I feel more concentrated...I discovered that the class is interesting in learning something, which I didn't believe.*

When I look back I can see that my focus was on my students. It's good in the sense that I want to do something good for them, I want to do them well. But when it comes to research I have a different view. I am afraid that this isn't action research. Back then when I did the action I thought it was, but today I can see that the students just were participants in a research project where I wanted to change the environment because I thought it wasn't good. Because I have been through a learning process I see things different now. Next time I will ask them more, involving them in a democratic process which is important in action research. I don't want to have a spectators view, but involve my students more in decisions which affect them.

I was wondering if my log contained questions which was too similar, because the students responded much the same on question one and two. What did you experience? What did you discover (opplevd and oppdaget) is quite similar in Norwegian. At the same time I can see that they didn't open up for inner reflections on the third question. It was too much for them on one day. And they are not used to do such reflections, this must be developed. I want to change my log, but I still want only three questions.

I realized that after the first action they put their finger to something interesting. They already discovered that they have a learning strategy, they told me about it and I need to pay attention to it.

7.1.4 Students log:

I had three questions in the log for the students.

1. What did you discover? *I discovered that a lot of the students in this class think alike... I discovered that a lot of us are thinking alike and that's creating collaboration.*

Both, teacher and students discovered that even if they don't look alike they think much in the same way. And if they talk together they can collaborate.

2. What did you experience? *I experienced insight in how the class is thinking... That the teacher understands us and that she knows how to treat us or we treat each other.*

When we talk about things and say how we want things to be, it's easier to understand what the teacher and student means. This creates understanding for how we are.

3. What did you feel now? *I feel that this challenge showed me how it is easier to be secure and happy...I feel that I accomplish something if I try.*

When you talk about conflicts, and listen to students they respond in this way. This student feels more secure and happier at school after we started these lessons with different themes.

In my planning I say I want to take the students feelings seriously. They have a lot of feelings, good and bad. I want to recognize their feelings and that it doesn't need to be scary with a lot of feelings, but even if it's not scary it takes a lot of attention. Then it became difficult to give attention to other things. Grendstad (1986) writes that feelings play a central role in the relationship to ourselves, our relationship to the world and the people around us.

At the same time I want to show them that there is a reason for why they choose this program at school. A lot of the students say that they discovered that almost all in the class had the same interests.

7.1.5 Significance of learning:

I think that the ideas of using pedagogical suns to show students that they have several things in common, creates a better environment. I can see that this made them think that maybe we aren't so different from each other anyway.

From their log I can see they got a common understanding of the class. They want to learn something. *That a lot of us think the same and have same goals...That we feel and think almost the same...That several people in this class had the same goal as me.*

These quotations also tell me that the classjustice is strong. I mean this is about democratic processes. Everybody is committed to what they do and think. They interact in relation to this justice who exists in every class. The students abide in the justice that lays silence in the classroom, but when we talk together and we share our thoughts and emotions, and it creates recognition in the individual. It is recognizable for everybody. It's easier to recognize yourself in others when you know their inner feelings and thoughts. And it's easier to accept the known than the unknown. And it's less scary, the unknown is scary. As Dewey writes we should try to keep the door ajar, but it's not easy. The justice will still be there but more harmless.

7.1.6 My claim on knowledge

They respond on me doing “my action” in a good way. *I discovered that Elisabeth (the teacher) is interested in our opinions...That the teacher understands us.*

I can see that working with the interpersonal relationship before subject to create trust is very important. And there isn't much I have to do to make my students feel better. It is Buber (Hiim and Hippe 1998) who writes about I-you-relationships. In this relationship we are equal. In this case it is immersion in another's situation, companionship, conversation and reciprocity, the most important and Buber calls this a dialog-relationship. It is basically this kind of relationships that takes care of the most human. I recognize that dialog and an I-you-relationship creates a great deal of trust between students and teacher. They also got a greater understanding on each other. And if the students also could create this relationship between themselves it would create a community with a greater tolerance towards each other.

In relation to what I write about class justice it's about developing democratic processes. When they learn something about respect and reciprocity this is to develop their skills to a base for democratic processes.

7.1.7 Changes:

In my next action I will change the questions in the log. I will be aware that we related to the psychosocial environment in these first actions and then I will relate to the professional part of the education. If we are creating a secure environment for our relationship between us, it would be easier to work with the subject later. I will be aware that the justice in the class is present and I will consciously act across this. This I will do to promote a democratic process in the class.

7.2 My third action - student participation

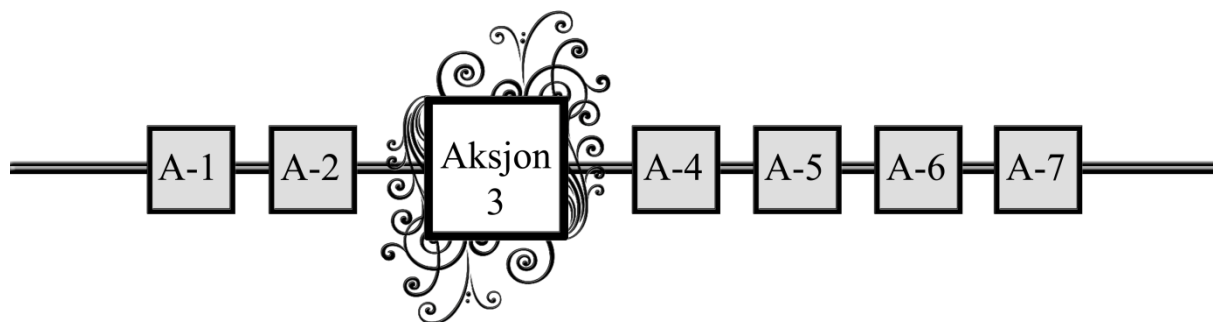

I decided to use one hour, every fourteen days to work systematically together with my class. I was focusing on changing their environment because I thought that would be better for them. Now I realized that I would change their environment because with a calm, secure and stable environment it would be easier to:

- Educate students to be independent and critical, and to have opinions about their educations and their own needs in everyday school life.
- Change the designs of the tasks in my subject. This I would relate to in chapter 5.

I started to wonder how the life for the students would be if we let them take more part in shaping the content of their school life. My thoughts were to talk more with them, discuss what they wanted to work with, talk and reflect more closely the goals for education and facilitate for increasing student involvement and participation in their own learning arena. The purpose of the work is empowerment and diversity in relation to the subject, and experience to contribute in their own everyday school life. And create an environment for democratic processes in which one feels that they are heard and seen, as well as taking their own school life seriously.

Earlier I was afraid for what I called a sheep mentality. I want my students to know what rights they have in school, and what mutual commitments the school and students have. I realize that I have to introduce this knowledge gradually because I can't expect them to deal with everything at the same time.

7.2.1 My planning:

Pupil participation is important in the Norwegian school system. Læringsplakaten¹¹ shall "Legge til rette for elevmedvirkning og for at elevene (...) kan foreta bevisste verdivalg og valg av utdanning og fremtidig arbeid" this means that the students need to be educated in a way so they can make conscious value choices and the choice of education and future work. I want to ask them what they think about this in our school and what it means to them. Is the school communicating in a good way that we like or want to have student participation? I will draw a pedagogical sun with this unfinished sentence inside - student participation is for me...

My goal for this lesson is to see if they know the concept. I want to invite them to think that this is important in relation to their own influence of their school life. I want to ensure that students experience democracy and student participation in their school life. I plan inception of class by saying something about the structure of these lessons, we should have contracts and contacts, and we will work with pedagogical suns which is about student participation. We will write log.

I'll write a narrative story from this lesson and take it back to the students. In this way I can get a confirmation that my interpretation of the lesson was as I said, and at the same time triangulating my data.

7.2.2 What did I do

I explain to them that we will use every other Thursday to introduce and to work with the concepts we need to, to improve our democratic environment. I explained to them what I mean by contract and contact. The contract should highlight the rules for the dialogue we are having. By enforcing the rules of the dialog, we contribute to order and democracy in the dialog. I also use the contract like this: I asked them to keep what we do in the classroom in these lessons within these walls. It is not because there is secrets we are working on, but because it creates a sense of security and confidence to know that we are not talking about the things that come forward during these meetings. The students agreed that this should be kept within these walls. Contact we can do in different ways. Today they will find a person which they usually don't talk to and tell this person about the last movie you've seen or another good movie you want to talk about. The reason why we do contact is to build relationships between us. I have previously pointed out the importance to create good relationships between us.

¹¹ Læringsplakaten is a part of the educational plan for students in Norway.

The students did this and there was much laughter and a good mood. We did this twice so that we could switch between different people you usually don't talk to. The student had thus moved around in the classroom and they didn't sit on their own desk anymore. I interrupted this moment by saying that they could sit where they sat right now, with the person they last spoke with and that we are now going to talk about student participation.

I draw my pedagogical sun on the board and wrote inside. *What is pupil participation for me....* The students got very quiet and I wondered what was going on. They said that they have never heard the word before! At the same time there is someone who asks very seriously about why teachers haven't involved students in this term before if it is so important for students to know about. They said that teachers have neglected their duties.

I must honestly answer that I don't know why this has happened and it's a pity and shame that it has. Luckily I have now told them and we should start to use it straight away. I said to them that we, the teachers, mustn't be so afraid to show our cards. The teachers don't need to be so secretly about everything, it's for the best to everybody that we sheer our information.

We're at the beginning of February, school year 2009 and now I discover that they have never heard of student participation before. I talk a bit about this concept and I took care not to add too much word in their mouth. I wanted them to think and discover for them self.

Students answered this on the pedagogical sun: *What is pupil participation for me...?*

I am allowed to say what I think, that it provides better interaction in the group, that I can get the teacher's attention, that I can influence the teaching, it can provide better communication between student and teacher.

There also appeared some critical questions around this concept student participation. The student said: *there is too much pedagogic in schools, too much understanding of the student, simply too little respect for both learning and teaching.* The student is quite critical, and advocates a somewhat old-fashioned view of how a class and school should be managed. The Cane is gone for good, thankfully.

Since the comments about respect came up we took an impulsively discussion about this. We talked about respect for themselves, for teaching and for the teacher.

7.2.3 Reflection:

This is what the students wrote in the log after the lesson:

1. What have I learned? *That respect is something that goes in both directions between teacher and student... What student participation is... The teacher and students in the class can have a good relationship.*

It was several of the students who wrote they learned what student participation is. They recognize that their voice counts for something. That it's important to know about such thing so that you can influence on your everyday school life.

They also write about respect. They recognize that they have to contribute to class environment themselves. And if everybody contributes it would create a good environment. They also write they can have a good relationship with their teacher. They haven't talked about this before.

2. What have I discovered? *That we should have respect for our own learning... That there is someone that actually cares about learning... That there are different opinions about student participation and respect in the class... That a lot of us think in the same way.*

When my students write like this, I think it show that they understand the need for respect each other and yourself. It also shows that they mean different thing with the concept respect and that we need to clarify the differences. They got it confirmed, like in the previous action, that they think similar. It shows that they found out its suitable to be open and honest.

3. What should I do for next time? *Shut up, be quiet, and respect teacher and students more... Think before you say anything... I think its fun when we do these things together to facilitate a better social environment.*

It seems that they start to realize that they have the power to contribute to their own environment. It seems that they want a change as well. My wish is to facilitate for my students to ask critical questions about their school day. The excitement lies in letting the students discover for themselves that pupil participation is important to them. I believe that students should have a full insight into what is the school's responsibility, what is the student's responsibility and how we can help each other towards a common framework for understanding this. CC requires a lot of both teacher and student, and none of us can do this alone. We have to use the dialogue so we can get a step further. I claim that getting students to actively require student participation in all subjects will spread a message to all teachers that

today's youth are not only "slobs" which I thought at first, but that they are conscious, reflective and working young people who deserve respect by the fact that they are seen and taken seriously by being involved in all aspects of their school day.

I was quite unprepared that it would affect their emotions in this direction. And not prepared for a discussion on respect. We got some strong voices in this class and sometimes they are not good listeners. Gordon (1979) writes about being in a position of active listening. It is the feedback you give to the others opinion, after coding their statement. Interpretation is important. But to be sure, you need to ask and that's the feedback. Grendstad (1986) isn't as fond of interpretation as Gordon is. Grendstad says that when you interpreters you are not objective and it easily can occur misunderstandings. But I guess that's why you ask and give feedback in active listening.

When looking back I can see that they liked working with the interpersonal relation. It seems to me that it creates good mood and good mood put us in a state of building relationships, which I have been writing about before. Relationship before subject/tasks/profession is important.

When I read their log I find that they are very concerned with respect. They write in the log that we can have a better communication between teacher and student and that they need to be quieter in the classroom. I wonder if there are any underlying reasons for why they are so concerned with respect. I can try to analyze my data, but I find it difficult to give a final answer. It would only be speculation, but I try anyway. And this is only my thoughts about this, I haven't asked my students. We have had and still have to some extent, poor environment in the class. With that as a starting point, I think that students feel trampled on by costudents in many situations. I know there have been many confrontations in other lessons with other teachers. Anyone experiencing such violent confrontations is affected in a negative direction. It is reflected in an insecure environment for both teachers and students and it doesn't create an environment where you are seen and taken seriously. That's why they think respect is so important.

7.2.4 Significance of learning:

It seems that students start to find out that working directly with the class environment can give different effects. In relation to the word student participation which they even haven't heard about they realized that if they know more about what affects their everyday life at school it could give them a certain power. And they have experienced respect for their own

and others' learning and not at least, in the relations they have to each other and toward me as their teacher.

I want to educate my students to be independent and critical, and to have opinions about their educations and their own needs in everyday school life. One student confirms this in the log like this: *I discovered that everybody wishes a better cooperation in our class and better communication between students and teacher.* This shows me that they start to take their own needs seriously. Other students say: *I discovered that a lot of us think alike and share the same opinion and that the class I honest about how we want it to be in the class.*

This comment show that I am in the right direction. The students are on the way to be critical and independent. They have realized that they can affect through student participation on their own school everyday life. When they say they want a better communication I believe they take their needs serious and say that communication cover that need. When they share their meanings and their thoughts, they discover they have the power to facilitate their own class environment and the school day.

Another student say: *I discovered a lot today... respect between students and teacher, and that the teacher is important....I discovered a new word - student participation.* I have facilitated for the student so that he discovers and tells me about what he have learned. This isn't a small thing for a student to discover.

7.2.5 My claim on knowledge:

Always expect unexpected thing, and that emotions can be strong. One of my student say: *You should think before you say something.* She realized this, because there were some strong emotions from other students after she said something quite unfair.

Another student say: *I realized that I have influence on the teaching, if I want to.* He discovered he have a power to affect teaching. If everybody recognizes the same, it would be fun at school. Maybe we got students which are critical to the content in teaching and how teachers are engaged in teaching. This will lead to many of us have to change the view of what constitutes good teaching, what is a good learning environment and how we can begin to realize our values in our practice. I claim that change occurs in you, it influences others to change themselves, which in turn affect others. This is what could be the new reform in Norwegian schools.

Students believe that to be seen and taken seriously are respect. So when I listen and talk with them, and do actions to improve their environment they see that as respect. I am aware that each time I facilitate for to see them and take them seriously, it is fertile ground for mutual respect.

7.2.6 Changes:

On the next meeting I will focus on the strict regime that some individuals want. I want us to deal with this in class which is our primary democracy when we go to school. It will also teach students something about the democratic process inside and outside the school. I would also empower students to take the provisions for themselves in the community. I want to advantage their critical energy and ask them to come up with a better and feasible proposal than using the Cane.

7.3 My fourth action – our roles through the day

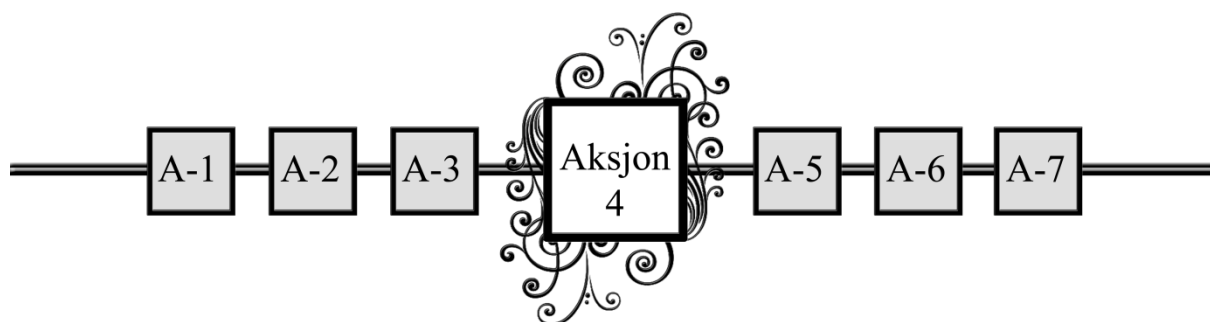

It was important for me to take my story about our third action back to them. When reading it to them I make it not only valid but they would also give me feedback on how I perceived the action.

I think that student participation is a part of democratic processes in our school community and in society otherwise.

The UN Convention the Rights of the Child, article 12 nr. 1, Education Act §1-2 and § 9a, and CC general part talks about this. This is an extract:.

Elevmedvirkning

Skolen og lærebedriften skal forberede elevene på deltakelse i demokratiske beslutningsprosesser og stimulere til samfunnsengasjement både nasjonalt og internasjonalt. I opplæringen skal elevene utvikle kunnskaper om demokratiske prinsipper og institusjoner. Skolen og lærebedriften skal legge til rette for at elevene får erfaring med ulike former for deltakelse og medvirkning i demokratiske prosesser både i det daglige arbeidet og ved deltakelse i representative organer.

Elevmedvirkning innebærer deltakelse i beslutninger som gjelder egen og gruppens læring. I et inkluderende læringsmiljø er elevmedvirkning positivt for utviklingen av sosiale relasjoner og motivasjon for læring på alle trinn i opplæringen. I arbeidet med fagene bidrar elevmedvirkning til at elevene blir mer bevisst egne læringsprosesser, og det gir større innflytelse på egen læring.

http://www.udir.no/upload/larerplaner/Fastsatte_lareplaner_for_Kunnskapsloftet/prinsipper_lk06.pdf

(16.03.10) This part talk about that school should prepare students for participation in democratic processes, encourage community involvement, and develop knowledge of democratic principles. Pupil participation means participation in decisions concerning their own and team learning. In an inclusive learning environment, student involvement works positively to the facilitation of interpersonal relationships, and motivation for learning in education. In working with subjects' student participation makes the student more conscious of their own learning processes, and it provides greater impact on their learning.

I think it's important for my students to know that the community requires a lot of us. And to practice democratic principles in school is a good thing, al practice are. It prepares you for the adult life with a lot of responsibility, which is different from the youngsters.

7.3.1 My planning:

Remind them of contract as at previous meetings. I will work with facilitating new contacts where we will talk about the different roles we have during a day. Work with increasing awareness of the roles that we have throughout the day. Maybe we also find it fun. At the same time it provides perhaps a better understanding of both own and others' behavior. Often it isn't easy to see the difference between roles and qualities. Specific roles are given specific characteristics and these qualities are the subject to value judgments. In this way it is that the specific roles are tied to our self-perception. Skaalvik and Skaalvik (1996) write that we can develop a negative self-perception and this show clearly in the school in different ways but often as a lack of self-confidence and lack of motivation. The student role contains several sub-roles which we should talk about.

I will bring the story about the last lesson back to class. I will talk about democratic processes in society, about being accessory whether it is in school society or society out of school and that we try out democracy in the classroom. Tell them it's a huge part in the law about education, who expect a lot of young people when it comes to democratic processes.

7.3.2 What did I do?

I reminded class about the contract we did last time. I did remind them about that each meeting will start with contract and that everybody needs to know this and agree about it. I started to read the story about the last lesson for my class. Here is the story I read:

We started to make a contract and then contact. You should talk to someone you don't talk too usually and then circulate and find someone else you don't talk too. You all did this with enthusiasm, there was much talking and laughing and I felt that the atmosphere was wanton and good. "I discovered some new aspects of some of the class" and "it is important to respect each other" are opinions that have been found in the log.

You could sit in the places you had found and I drew a sun on the board that said "What is pupil participation for me". Then we discovered that almost every one of you didn't know what the word meant and I explained a little around what my thoughts were. One student wondered seriously why the students in school haven't heard about this word "student participation" earlier if it were important for the students. Several of you said in your log that you have "learned what student participation is" and "that we have influence of our own school everyday life". We talked a little about student participation, and afterwards we wrote up what you associate with that term.

Moreover, it came up a number of critical remarks that made contributions to other discussion topics. Such as have respect both for yourself, the teacher and the teaching. "It is important to have respect for each other and be able to trust each other", "I have learned that it is not just me that see the same things in class when it comes to there should be more silence in class". It came up during the dialog that everybody wanted it to be more silent in class during teaching and the logs also confirms this. Moreover, there are many who say "I've found that students have too little respect for teachers". Some of the students emphasize "a better interaction in class and better communication between teachers and students".

They nodded in recognition. I think that since there were no objections to what I read to them my perception of the last lesson is as described. I continue to talk about roles that I have from I woke up in the morning until I got to the school. That is many different roles in a few hours.

I illustrate how the roles can be mixed together using my mother's voice to my husband and my girlfriend voice of my colleague. The atmosphere is good. Students sat together in pairs, with someone they don't talk to usually. They tell each other of their roles. The mood is still good.

I see how important it is to show them the different roles we have through the day. Sidsel Tveiten (1998) writes that by showing their roles to others they provide insight into aspects of themselves and how they affect others. You can achieve a greater understanding for both themselves and others and can by this detect the need for changes in their practice. In this context, in their own class. And as Skaalvik and Skaalvik (2005) write the student role contain several sub-roles.

Before I got to my main subject which were the sub-roles, my students started to talk about the topic of respect. I was easily sidetracked so I asked them; what do you mean by respect? *Respect is to be quiet in class then you respect the teacher and the teaching...Respect for myself and my learning are important...Respect is to listen to others.* We came to a lot of answers, this is just a few.

It evolved into a discussion about who spoke when and where and accusations rained. We had a pretty loud discussion. The students began to shout to each other. Some were angry, some were very quiet, and some began to laugh. One student had really put her opinions on the table; she felt that someone in this class was talking behind her back. She explained that when she came into the classroom it got quiet. In particular, it was a lot of the girls who felt this way.

Others commented that some students are talking in each other's mouth and they talk in teacher's mouth all the time. Since the discussion was quite loud and one student started to laugh at something another student said, and couldn't stop, I sent the student out. I thought that the student could laugh himself finished outside, and that it was disrespectful towards the others to laugh at them. We had to stop there because the next class should start. Some of the students came to me wondering if my experience of them was like it was presented at the meeting. I had to watch what I said because the students are quite vulnerable, in my perception. And it's also about respect.

We forgot the log.

7.3.3 Reflection:

I wanted to talk about all the different roles we have during one day because I wanted to show them that every one of us juggle with the different roles we got. And that I sometimes still am a mother when I come to my class. And maybe some of you are an angry sister or a disappointed daughter. This role we're having reflect how we are facing each other when we meet. And maybe we develop an understanding of how we are doing before we take the role of a classmate or a teacher.

At the same time I wonder where it has become of respect for each other. I find it missing in this class and so are my students. I need a new meeting quickly. My students need to talk through the problems. This felt just like "markboksen" the worm box in SØT-model. This is a box with worms in. The worms are everything said and done. When you open it, the worms start to crawl over the edge and you can't put the lid back on. We need to highlight the misery in this class. This is not a problem but need attention. According to Hartviksen and Kversøy (2008) does experience show that when the misery is made visible, will mechanism of displaced and resistance occur. I know when the lid is of the box we need to talk through every worm in the box before it get better.

When the discussion occurs I found the discussion difficult to stop. I didn't have any strategies to use when I wanted to stop this discussion. I know there is a tool in SØT-model which is called STOP, but I haven't told my students about this tool so I felt I couldn't use it. They wouldn't even listen to me in this discussion, I think, because the lack of respect for each other and me, and for the situation.

7.3.4 Significance of learning:

I think they experienced to be insecure in the meeting with people who creates discussion all the time. And I see that talking together help they understand each other and to feel understanding for that others maybe has a difficult life out of school. Dialog as a tool is important to create understanding.

7.3.5 My claim on knowledge:

That highlighting the misery makes us insecure and discouraged.

Through listening can we create a better understanding. Several students start to think about listening as a good thing, before they were talking about talking with each other as an important thing. I think when they realize that listen also is important they had come a long way.

One student writes in the log: *I talked about my different roles to another person which I usually don't talk to...I understand that the different roles we have during the day isn't easy roles...Talking together create understanding.* When my students understand more of each other and about the processes going on between them, they create a common understanding and a better environment can grow.

7.3.6 Changes:

I decided to try the tool “stop” from SØT-model. I want to use this tool to create security for the students in a discussion. It gives me the right to terminate the discussion when it becomes unfair and degenerates in some way.

7.3.7 Next meeting the following day:

After the previous meeting they were quite upset. I told my students how I experienced the previous meeting. It wasn't nice that some students felt that there was talking behind their backs. And this was not respect for each other and each other's feelings. Only you know how you feel, and we should respect that, especially when someone tell you about their feelings. This is a phenomenological view towards my students. It is only you who have exclusively access to your thoughts and feelings and can tell others about what you feel. We should respect this and listened to what the other has to say.

One of the girls said something about how the meeting felt yesterday. The class is quiet, but then one of the boys apologized. This breaks the ice and we have a good conversation about how it is perceived to be in such a conflict, how it is perceived to be part of such a conflict. Everyone speaks in turn and the students listen to each other. I reminded the students to write log.

This is what the students responded in the log this time:

1. What did you do? *We talked about the roles that I have just before I come to school... We talked about respect...I listened to some people who more or less were only concerned to advance their own opinion rather than listen to what I had to say.*

This tells me that we are in a start phase of the work to improve the class environment. It is a slow process that requires constant maintenance. I see that my students are still concerned with respect or maybe the lack of it. And they start to realize that listening is important. When you listen it creates understanding and tolerance for each other. And then you start to create relationships.

2. What did you feel? *That I actually was not aware that I had so many different roles...The class should have a better understanding for each other...I felt the honesty of the others. I feel that we should listen more to each other and not talk in each other's mouth all the time.*

When we talk about our roles outside the school and in the school you create an understanding for how different our everyday life is. It's all about talking and understanding of the differences we have. And it's about accept and accepting differences. Hartviksen and Kversøy (2008) write that to highlight the differences and inequalities are necessary to show that it's not dangerous, but maybe scary, to have differences.

3. What did you discover? *The fact that many of the roles were not so easy, and that we can make some parts easier by being a good classmate and not expect too much of each other... I discovered that if you talk about things you can get out what you want to say.*

Some of my students start to realize that talking is good, the same with listening. This is important tools to use in your life generally. I believe that when you discover this early, it puts the basis for developing experience and expertise within this field. And it's this Johan Galtung say is a great peace tools. He said that in peacetime this is one of the most important tools we have, to listen and to talk together.

4. What is it wise to do? *To listen to what others have to say and not just be concerned with what I want to say...In the future, it is wise to continue to be open and honest and talk about stuff that includes the entire class...To speak out about things like that, so there are no problems later.*

For me the last sentence confirm what Hartviksen and Kversøy (2008) says about the worm box. If you keep on talking all of the ugly, crawly worms will disappear. You talk them to death.

7.3.8 Reflection on the logs:

It appears that the students are not afraid to take up things in the classroom. They expect in fact that the others are honest about their feelings and how they want it to be in the classroom. *In the future I think it's wise to continue to be open and honest, and to talk about thing which concerns the whole class.*

Some are more committed and some are not willing to reflect on what happens here. *I felt that the lesson was a bit boring, do not know why, but it was a bit boring.* At the same time the same student writes that *such conversations are important.* It confirms what I'm thinking about that some students can't or won't reflect when there are conflicts. And it confirms that we are a contradiction. On one hand it's boring one the other hand it's important with talking.

7.3.9 Significance of learning

When I read about the action I think its one thing nobody noticed before. One boy actually in front of everybody apologized for his behavior. This must be the biggest proof of growing respect. Another student say: *I think we have to accept that people are different in our class.* If they understands that to be different from each other is ok

If students agree that there are differences, but accept that we can live together anyway, they have begun to understand the democratic processes that exist. I mean that it exists in our multicultural Norway and school a lot of differences which we must accept. We must understand that this doesn't entail a threat to society as we know. The society we know it's about to change radically.

7.3.10 Claim on knowledge:

Words like listen, honest, open, including, talk about problems is words coming from my student's log. I believe that my values start to get more appeared in my teaching and this affects them. This facilitates them to change as well.

They say to me that when you can talk, you can solve problems and when you listen, you create an environment for a growing understanding and accept for each other.

7.4 My fifth action – conflict and cooperation

Action 5 and 6 we worked with about in the same time. Action 5 concerns the environment and action 6 concerns the subject task.

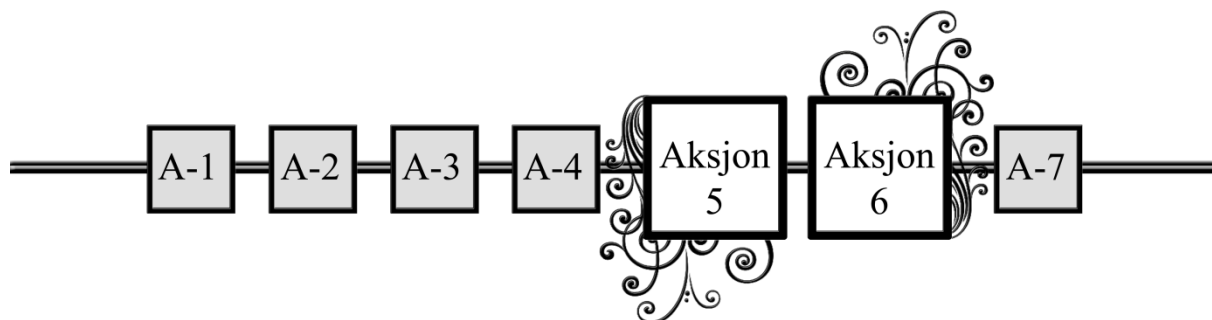

Hartviksen and Kversøy write about conflict and cooperation like this.

“Vi opplever at både samarbeid og konflikt avler spenning. Forskjellighet og uenighet er kjennetegn på at vi er i samarbeid og konflikt. Forskjellighet og uenighet genererer spenning. Spenning kjennes i magen”. (Hartviksen and Kversøy 2008:93)

They say that both cooperation and conflict breeds tension. When we are in cooperation and conflict, it is characteristic to feel diversity and disagreement. Diversity and disagreement generate tensions and tensions are detected in the stomach. By showing the differences we are ensuring that the inequalities are more tolerable. It's there even if we don't like it. Students have already experience a variety of different discussions and opinions. They have different perspectives on the discussions and opinions that have been thrown out in the classroom. This is a challenge for cooperation. Conflict arises when differences and controversy are great. We need to make visible differences to be able to withstand them. And we still have a need for dialogues.

There is both cooperation and conflict in the class. But are the students aware how close these terms are to each other. I want to ensure that students will gain a greater understanding of the concepts and the situation in class. I want them to understand that talking about the past isn't constructive. Then there will be many questions about why did you do that? You should not have done that, and it's the source of more conflicts. And I want to use pedagogical suns.

7.4.1 My planning:

Remember the contract. Talk about I-language. I think it's important because they relate to the case better or easier when we say I instead of mon or we. Hartviksen and Kversøy (2008) claim that when you use I-language you speak on your own behalf, and it appears that the use of I-language you tend to take more responsibility.

We will work in groups of three and three, with two pedagogical suns. You should write down what cooperation means to you and what conflict means to you. The result will be written down at the board. I should be aware that this shows differences and inequalities and can create discomfort. After this I want us to discuss what we should do to improve our cooperation. I want the result to be like how we want it to be in our class. I think that the result of the discussions would say something about our respect and tolerance for differences, but still we want to cooperate. We will learn about conflict resolution, cooperation and learning strategies to be a full member in a democratic world.

7.4.2 What did I do?

I reminded them of the contract. That everything we say would stay behind these walls this creates solidarity as well. I tell them that I want us to talk I-language and the reason for it. The students respond to this by saying *I do agree...and I haven't thought of that before*. We all agree to continue to say "I". Then I devised them into groups three and three, I gave them a sheet to write on and they talked about conflict and cooperation. Everyone had to say at least two associations with these words and they wrote all down at the paper. I asked them about what they wrote, and as they told me I wrote it down in two columns, on the blackboard. I started to talk about the word conflict first and then cooperation. This is what the students proposed.

What is conflict for me:	What is cooperation for me
Prolonged discussions	Disagreement
Disagreement	Working together
Lie	Helping each other
It can lead to a fight	Respect and understanding
Enmity	Listening to each other
Argumentation	The difference in effort
Discussion	Commitment
Talking about others	Tolerance
No objectivity	Diplomacy
Lack of general discussion knowledge	Communication
Frustration	Conflicts
May be constructive	Different perspective
Not relevant arguments	Solutions
Different angels	Compromise
Narrow-minded people	Open to others opinion
Stupidity	Take initiative
Word war / polemic	Getting over disagreements
Not listening	Don't run over others
Unintelligible	We do what we do for benefiting the group
Meaningless talk	Respect to others opinions

I ask them what they saw in these columns. It was quiet for a while before one student raises his hand. The student say: *It's much the same, it looks like the same.* What does it mean to all of you in this class? *Well, we need to relate too many of the same things when we work together and when we have a conflict.*

I ask the class about how we want it to be in our class when they realized that they are thinking much the same about conflict and cooperation. Students discuss and I am writing several proposals on the board. We agree on these points:

1. We should be more friends
2. We can be quieter when someone talks
3. Open windows, we need more air

I will just refer what we were talking about:

1. Being friends is a point that no one will commit to. We agree that we should respect each other, but that we can't require everyone to be friends. They feel that the difference is too big.
2. We shall look after ourselves and be quiet when others speak. This commitment we make to ourselves and to the others. I want to make a closure on this agreement and everybody says yes, we agree to take this commitment serious.
3. We will open windows in the pause. When lesson have started we open windows by agreement between the students and the teacher. If it's very cold the girls should get dressed. And the boys will not open windows just to "freeze" out the girls.

Suddenly we got an argument between two students. I will not go in detail, but it was unfair and unnecessary and I decided to use a tool called "stop". The argument came very suddenly and did create an uncertainty among the students.

I reminded students that they should write the log:

7.4.3 This is what my students wrote in their log

1. What have I done today? *A discussion about what is the difference between cooperation and conflict...I have listen to a loud argument between some students in my class again.*

I can confirm that they discussed the difference between these two words. It seems that they felt this was interesting work. And I can confirm that it was a loud argument about respect again, with the same student as last time. And from the writings in the log I can see that the students start to get tired of this. They use the word *again* a lot in the log when they refer to the situation.

2. What have I discovered today? *If we have arguments in class we can talk about it and solve the problem in these lessons...I have discovered that the class has similar thoughts around conflict and cooperation...I discovered how important it is for the class to cooperate with each other, and that we can have a good relationship.*

It seems that when they have a discussion they understand it's easier to solve the problem by talking together, this also involves listening. They have been aware that the words conflict and cooperation are quite similar and that it involves making the terms harmless. The understanding also increases in line with insight.

3. What is it wise to do next time? *It is not easy to be friends, but we can be good classmates. To listen to others before one interprets the way you yourself would interpret it, it is not always the facts that you yourself interpret or think...That one can have respect and tolerance for each other.*

It seems that they realize that you don't need to be friends with everybody, but you can have respect for, and tolerate each other anyway. To take care of yourself and your own talking is a good thing and by that shows other respect.

7.4.4 Reflection:

I am pleased that the students saw that conflict and cooperation are two sides of same coin. All this things they wrote down at the board is tools to student participation. When you highlight the differences and inequalities in this way, you put your finger on that the conflict can be a source of constructive coping. Differences contribute to the feelings aroused writes Hartviksen and Kversøy (2008). It is consistent with what Grendstad (1986) writes that the recognition of emotions is important in relation to confluent education where the students learn to know their feelings. Student participation is a prerequisite to ensure the learning

conditions. It looks like when the words are written and made visible in front of you the words aren't so scary anymore. It is important to show the students that they look different on both cooperation and conflict. There is no reason to disagree when they see that they believe different things about collaboration. I think it has to do with the word itself, collaboration provides generally positive associations. Disagreement and diversity reflected in descriptions of both cooperation and conflict

It was good for both parts that we got some "air rules". I found it easy to use the tool "stop" from SØT-model when the discussion developed. I will continue to use it if the discussions degenerate.

7.4.5 Significance of learning:

This shows me that they realized that conflict and cooperation are much alike. Here are some of the words they wrote on both sides in the column: disagreement, communication, different perspective, discussions, and conflicts.

These words can be placed to strengthen their own thinking and their ability to reasoning. They can communicate their personal experiences and describe their own opinions they put in these terms. When we share like this, we give opportunities to display a variety of descriptors and perhaps become more reflective in different situations.

7.4.6 Claim of knowledge:

I know that being in cooperation and in a conflict setting different tracks. Some are good at managing both, while others think it is difficult to handle. You can recognize both, because it sets up tensions in many and some may also experience this as constructive tensions. In my class I want them to be able to recognize feelings about this and even draw their own conclusions if they can change the situation that is uncomfortable without going in a direct confrontation.

7.4.7 Change:

Next time I will reflect more around these words and make my students aware that we use reflective communication to develop new ideas about our cooperation without conflicts.

8 WHAT COULD I DO AND WHAT DID I DO? PART II

In Part I, I describe actions involving the learning environment. I tried to facilitate for the students themselves to become aware that it is only they who can change themselves and their environment. They need a larger base of acceptance and tolerance in order to understand and accept differences. In this way they can get a better learning environment.

In Part II I will describe actions which are done to change tasks of subjects. At the beginning I wanted to facilitate a better learning environment, now I wish to see if changes in the tasks I give them increase their activity in relation to Grendstads (1986) to learn is to discover.

My values are denied to come alive in my workplace and somehow along the path I try to ease my uneasiness. And I got an understanding from my “workplace” that it’s not ok to do these actions. To overcome these obstacles and to survive I took a decision to work more behind closed doors, so to speak.

8.1 My sixth action- swim or drown

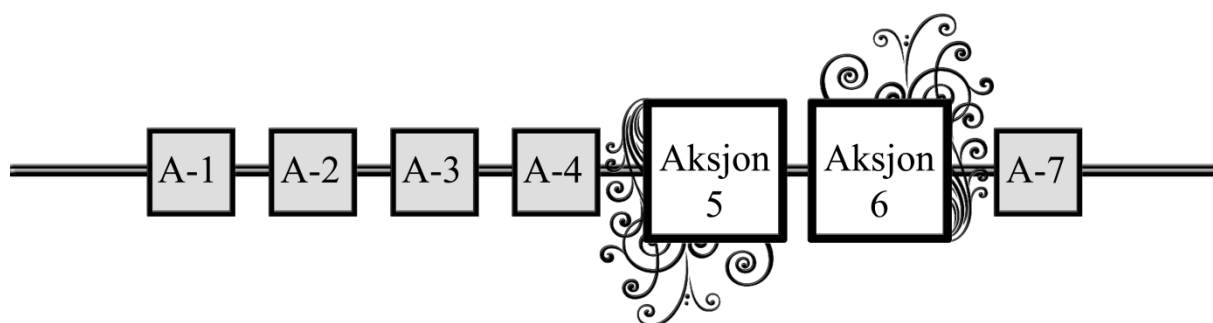

When the teachers gave tasks to the students, it had strict criteria of how the students should solve it. It doesn't give the student any room for reflection for themselves. But we wanted them to write a long rapport to explain their actions were they reflect also on actions. They tried, but I wasn't satisfied because there was a lot of “I did this and then I did that”, without explaining the reason for what they did the action. (Sounds familiar eh..)

I wanted us to write our tasks together and use our educational goals in the writing. My first action was taken by intend to increase their ability “to swim and not drown” when I gave them the educational goal and asked them to act upon this.

8.1.1 My planning

No planning at all. I was in a phase where acting impulsive was widespread and I like to think it was a good way to act in this state of the process. It's a lot of reason why I acted without planning and one thing is my own working environment. I had little control over my own teaching situation because I share class with a colleague. I think my action was a response on for me a strict regime. I feel like an impressionist in the 1800 which was a response on the dominant and academic salon art, which was subjugated to strict rules and custom designs. They wanted to confront the nature impulsive and direct. And my action is like that. I confront the nature, my class, impulsive and direct.

8.1.2 What did I do?

I gave them the educational goals, 34 goals from CC and asked them to share the goals between them in groups, three and three and act upon it. They were confused, very confused. They asked me what I wanted them to do and I said that they had to figure it out themselves. "Write your own tasks, use your educational goals" were my answer. I wanted to give them a big space to work in were they could be creative.

8.1.3 Reflection

Of course it was a disaster.

How could I believe that they could swim when I haven't thought them to do so? The result was that only two students delivered a finished task. The rest looked like they were thrown in to the sharks. I've heard about youngsters thrown in the water, and intuitively learned to swim. And I thought the same, I thought they would learn to write the task if they talk together. But I realized that they didn't have the same view as me and I really hadn't facilitated for this to happen.

Even if I believe that students can think for themselves and that they are capable to discover for themselves I realized that it has to be a golden way of doing this. From working on strictly framed tasks to "fix your own task" it can be a huge gap. The respond from my students was that they couldn't answer the task because they didn't know what kind of answer I wanted. This told me that they often answer what the teacher want to hear/see and they don't do anything for themselves. It had to do with rates they told me.

I think is about challenge Vygotskys proximal development zone. And this is a short version of a part of Vygotsky theory. Vygotsky means that development goes from the social to the

individual. That's why the child is able to perform an action in interaction with others before it is able to do it all alone. The child does things with help at first and then alone. You ask yourself what the child is able to perform on its own to find out what the child's ability level is. We must clarify what we mean the child might have done with help and support and what we think the child can do alone. My thought was that they were capable of doing this, I called their proximal development zone not in a good way. Next time I will think of what kind of performance are they used to and have they done this before. Most likely they are not capable to do it alone. But if I ask them to do it together with someone and the teacher are willing to help, they would develop and at last they can do it alone.

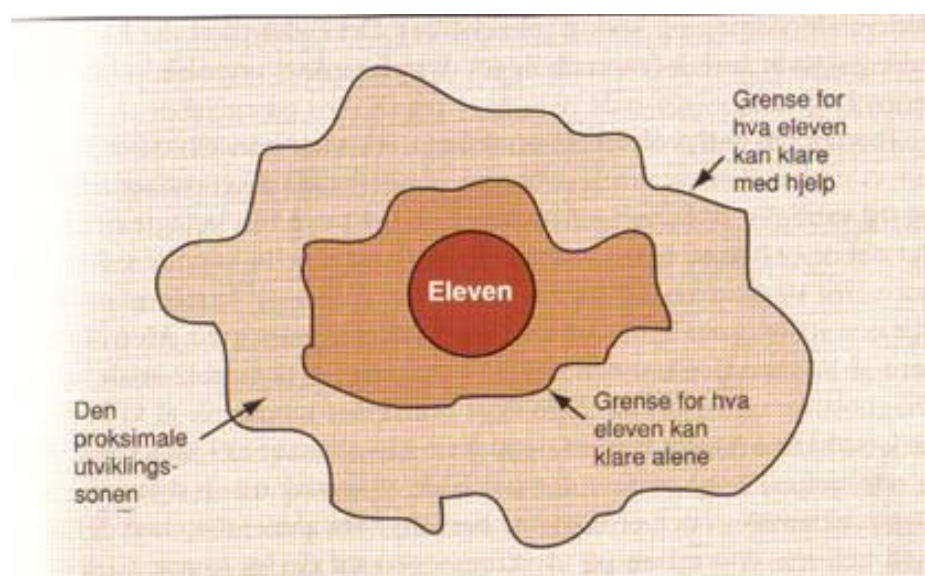

Figure 3 Vygotsky's proximal zone for children. (Imsen 3009:159)

8.1.4 Reaction from students

My students told me it was unstructured and poorly organized from me. I agreed. I haven't thought about how this task should be, and how it would be for them when I gave them a loose task like this. I choose their groups, and they didn't like that. They told me that I said to them that I wanted to use dialog in class and then I didn't talk to them about how the groups should be. They wanted to decide for themselves. They decided that they who know they wanted to be together in a group joined in. The names that were left we put in a hat and chose in this way the groups. This worked well and I think it's because they decided it for themselves.

I think I had the difficult part because I had to deal with my feelings around that my suggestion wasn't good enough for them. In that situation I needed to change my opinion about how the task should be.

I decided to have an informal conversation with the class because it seemed that they were not happy after this disaster of a task. I planned my question but at the same time I know some of the feedback because they told me when they worked on the task.

I will just clarify before we used to write task to the students with educational goals from CC. This is 34 different goals which cover this entire field. Now they could use this goals for themselves to write their tasks.

I asked my students:

1. Did you recognize any difference from previous tasks?
2. What was the difference?
3. How was this task for you?

They answered like this:

1. *It was a big difference from our earlier tasks, now it was so loose that we had to define our own task. It was little control from the teacher, too little.*
2. *The difference was that now we had to do everything by ourselves, earlier everything was controlled to the smallest detail.*
3. *The task was difficult to work with because we didn't know what was expected of us. What about a ting in between?*

At the same time there are a few things I wanted to improve as well. It is to ask the students more about how they want to do things which concern the tasks. I want to ask them questions like this; how do you think about this? Should we do it this way or that way? What about this? Sound this all right?

If we use dialog in matters which concern the tasks for the class I will get them more active in the process of writing their own tasks, working with educational goals and assessment of the task. I also want to generate interest and motivation for their learning.

8.1.5 Significance of learning

I believe in that the students are able to manage to work with the educational goals. They just need to be used to this way of thinking and working. I need to be closer to them, as a supervisor, for a period so that they can create their own strategies for how to handle the new

way of thinking. I need to challenge their proximal development zone in a way that benefits the students, so they don't trip and fall.

8.1.6 Claim on knowledge

To be challenged on the habits creates insecurity and uncertainty. (Dewey1916) To introduce new methods to work with educational goals in this way without telling them what to do, do creates insecurity. It is better to facilitate a looser structure little by little. Dialogue in this context is very important. We can talk together and find solutions together, and in that way solve the problem or the task.

When we work in this way you can use your interests when you solve the tasks. This will creates motivation and interest for the subject as well.

8.1.7 Changes

Next time I would design the tasks so that we take better care (ivaretar) of the students. To find out how knowledge becomes more understandable and applicability so that the students will feel that the tasks is more relevant, I need to ask them. When I know this I can facilitate the students to write their own tasks. My concern is that we are not able to engage all students because the knowledge we "give" to them is irrelevant to them. This is what I want to do, but the conditions are not there yet. I shear subject with a colleague and we do not agree on how we should do this. After this disaster he came to an understanding that it would be better for the students to work as we always did. I must say I chickened out; it was the easiest way for me in the moment. This year there has been some changes.

8.2 My seventh action – my questionnaire

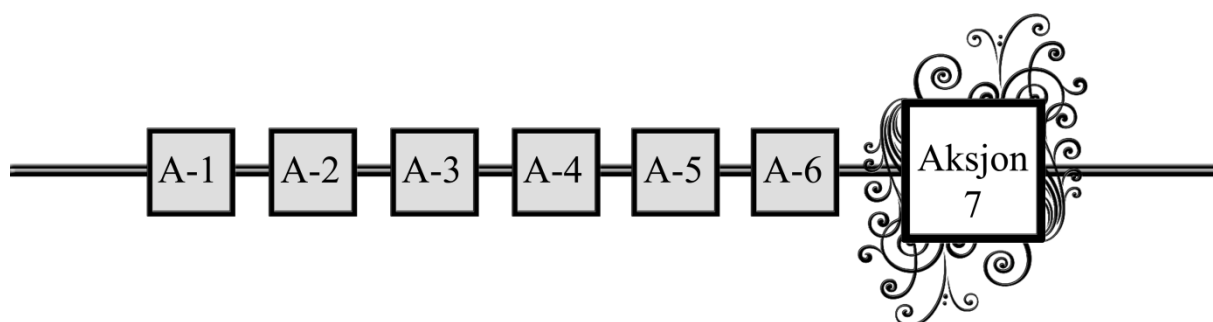

This is a qualitative survey I did at the end of the school year 2008/2009. The goal of this questionnaire was to determine how they had experienced this year of research, or initiated action from my side. The purpose of why I'm asking them is to know where I can make improvements in tasks as well in the lessons I used to work with different themes like student participation, roles, democratic processes and so on. I will hopefully get answers so I can facilitate the increase of learning, coping (Deal effectively with something difficult) and motivation in everyday life for my students.

Next time I probably would have designed the questions different. I can see they are too little close to the themes I had in the lessons. Still I see that my questions are in line with a qualitative design. Qualitative designed questions are life closely, about the students' everyday life. I am interested in the unique, and the contexts and structures instead of variables that can be measured in numbers, which can be a quantitative survey.

8.2.1 The questionnaire

When you do research you should be aware of your values. It is obvious to me that you need to be aware of your values when you do research together with people, or else you can have some problems of ethical character. I want in every way to be aware that I don't use people as a means to achieve certain goals. One must at all time strive to protect the mental and physical integrity of individuals in the research project. According to Holme and Solvang (1991) you always through a research do something about the people who answer an inquiry. You can start processes in people which you can't follow up, or they can disclose things they don't want to. "En kan sette i gang prosesser hos svarpersonene som man ikke har muligheten til å følge opp eller de kan utlevere noe de ikke har tenkt å si noe om". (Holme and Solvang 1991:34) I really don't want this to happen, so I will be careful when I choose the questions. Anyway it's necessary to know and to be aware of such a problem could occur.

The first draft of the questionnaire looked like this. Questionnaire Draft 1:

1 A. What period did you like best?

A. (aug-des)

B. (jan-jun)

1 B. Why?

2. How did you like this way of structuring the school year?
3. Do you have any suggestions how we can do it differently?
4. Which task did you like best in aug-des?
5. Which task did you like best in jan-jun?

6. What subjects do you like best and why?
7. What class during the school year did you like best?
8. Name three episodes that you remember most from the school year that have been?
9. What could you wish for more? (Mention the subject)
10. Something I remember well? (A golden moment)
11. I experienced the sense of teaching when
12. I experienced the sense of school life when
13. I experienced when coping
14. How have you experienced the sessions when we worked together on various topics?
15. What are you thinking as we have worked with different themes?
16. What could you wish for more / less of?
17. Some topics you want us to take up?

8.2.2 Changes to the questionnaire

When I did some adaption to the form I added some few questions. I also changed the order of the questions. I structured the form and sheared the questions at two sheets. I wanted them to fill out one sheet first and the second one a few days later.

Evaluation for the school year 2008/2009

This is an evaluation of how you have experienced this school year.

There are four parts, part one and two on one sheet and part three and four on second sheet.

We will use some time to fill out the two sheets in the sessions ahead.

PART 1: GENERAL INFORMATION ABOUT YOUR SCHOOL EVERYDAY LIFE:

1. Mention a golden moment?
2. Name three episodes that you remember most from the school year that have been?
3. Which individual class during the school year did you like best?
4. What subjects do you like best?
5. What could you wish for more?

PART 2: ABOUT MY SUBJECT:

6. What period did you like best?

A. AUG-DES

B. JAN-JUN

Why:

7. Which task did you like best in Aug-Des?
8. Which task did you like best in Jan-Jun?
9. How did you like this way of structuring the school year?

Explain:

10. Something you might want?
11. What do you want more of?
12. What do you want less of?

Part 3: DIFFERENTE THEMES IN SESSIONS

13. What are you thinking as we have worked with different themes I some lessons?
14. How did you experience these lessons when we worked together on different themes?
15. What could you wish for more in these lessons?
16. What could you wish for less in these lessons?
17. Some themes you miss in the lesson?

Part 4: OPEN REFLECTION

18. I experience meaning in my education (any subject) when?
19. I experience meaning in school life, when?
20. Give an example of an incident where you experienced coping?
21. Is there one thing you've discovered this year (anything)?

8.2.3 What use did I have of this questionnaire

This form was made and used a year ago. I found the questions relevant back then, but next time I would relate the questions direct to the themes we have been working on.

Part 1 is about the generally school day. They tell me they have fun at school, they don't mention subject at all, but other funny incident at school. This questionnaire was filled out in June and they have to think back. I think it's positive when they remember a lot of nice things that happened through this year.

Part 2 is about my specific subject and would tell me which task they liked best. I also asked if there was something they wanted more or less of. The result was that different student liked different task. The various tasks satisfy different students. I asked them how they liked splitting the two subject, one before Christmas and one after Christmas. They wrote they liked the structure, but later they told me it was boring to have many task in the same subject after each other. Some asked for more feedback from the teacher during working with tasks.

Part 3 is about the lessons where I introduced different themes we worked with.

Part 4 is an open reflection part.

I chose to give a short review of what I think is important from my students in part 3 and 4. I think this is relevant evidence of how we have improved ourselves.

8.2.4 Students say:

I will begin with a dressing question 13 and onwards.

13. What are you thinking as we have worked with different themes in these sessions? *It is nice with a good dialog and that we can share meanings...we didn't use to have dialog, but a lot of arguing...I learned a lot about the other students, about their meanings and their feelings.*

I feel satisfied after I saw this. It confirmed that I have facilitated for improvements in the environment and in the interpersonal relationships.

14. How did you experience these lessons when we worked together on different themes? *As social and instructive about how the class can get a better environment...I have experienced it positively because we got to talk about some problems...people have said their opinion.*

My students realize they have an opportunity to speak out, this creates democracy.

15. What did you wish for more? *I want more structure and respect...discussions about school and homework.*

They want more structure. This tells me that they haven't understood the consequences of their own behavior. I want to facilitate for my students to learn is to discover and I haven't done this good enough yet. Next time I will work direct with action-reaction. And what kind of consequences it can occur.

17. Some themes you miss? *More focus on the subject...I think the themes are good and relevant.*

I have worked a lot with changes in environment and less with subject. It is good that students ask for more work on the subject. I believe that you need to have a good relationship before you can start working with subject matter.

18. I experience meaning in the subject when? *When I understand and when I learn...when I learn something new...when teachers are in "learning away-mood".*

I need to a better facilitator, because then they experience that it is easier to understand and learn. They need to get thing more organized so they can master themselves.

19. I experience meaning in my school life when? *When I can go home and feel that I have learned something...When I learn something new...when I understand things...*

It is quite clear to me they want to learn and understand.

8.3 My eight action - my first free task

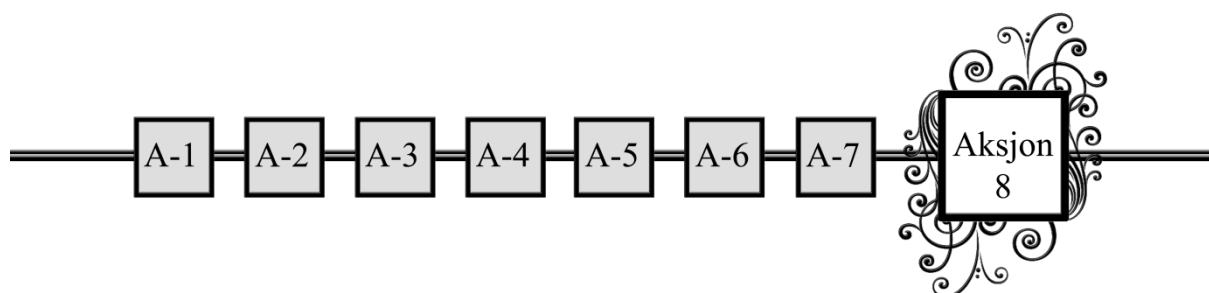

There have been some changes during the summer and when the students started in second grade, fall 2009 I don't share my class with anybody. I am free to do whatever I want to with the task I give my class. I feel free!!

I started right away to tell them how I wanted it to be in our class. I think dialog is important. I want to talk to them about how we should solve tasks, how to work with educational goals and how we can make knowledge relevant to them in my subject. I want to show them my cards. I don't an answer to every question they have. I can be a tutor and guide them if they don't know where they are going. And I want to be there for them in every way. I want to create trust, fairness and honesty, and I want to be a stable adult in our classroom. I want to create a good relationship and a good environment before we start working with tasks.

Today it is spring 2010 and when I read this I really see what I want to happen in class. It is my student's voice I want to hear, not mine. Next time I will ask them how they want it to be in their class, how they want to solve the problems of the tasks. I see I want them well, to be a tutor and not an oracle and to use dialog. But still it's difficult to let go of what I want things to be instead of asking my students of how they want things to be.

8.3.1 My planning and what did I do

In this subject we work with themes which can last four –six weeks. I plan the task to last about six week. It's relevant for what kind of task we do, because it involves a finish product. The task is divided into two parts. The first part they have to search for certain things on internet. I gave them keyword and some url's. If you find something within this area that you think are interesting, then you read more about it. Afterwards, we will share the information we have. In this way you can read what you think is interesting for you and you will share that information to the rest of the class which has probably found something else who's interesting for him. You won't have the rest of the task before this part is over. I want you to read and reflect over what's in this for you.

There was some frustration because they wanted to know what's coming after this. I carefully told them again what my intention was. They calmed down after some more instructions and worked quietly for a long time. I could see that every one of them went on different pages on internet and found different subject material.

Then we shared the information. Everyone had something different that the other. And they got practice in talking loud in front of the class. Then I gave them the rest of the task. We had some discussions of how we can interpret the task. We talked together and found that you have the solutions yourselves. I would listen to why you decide to solve the task this way.

8.3.2 Reflection

They responded well on this task. I think they respond well at my behavior as well. It was a task which contains one free task and one task with some directions. They said they had few frustrations this time, and that I had taken good time to explain the reason for doing it this way. They told me they liked it. I, myself liked it as well. I felt calm and relaxed and confident that this is more right than what I been doing before.

In my action called *swim or drown* I write something about a child proximal developmental zone. When I give them a task which contains some frames and some optional tasks to do, I facilitate them to get developed in the proximal zone. I, as Vygotsky, am concerned that the students gain challenges. Vygotsky in (Imsen 2009) says that the teaching is good only when it's running ahead of development. But it's not easy to teach in this way.

Students log:

What did you feel? *I felt it was difficult in the start, because I didn't know the rest of the task... It was fun...I wasn't frustrated even if I didn't know the whole task.*

I can see that my students think it was both difficult and fun when they got this task. And even if I try I can't satisfy everybody. Generally I must say that several of my students liked the way this task was designed. I will try to ask my students even more about how they want to design the tasks.

What did you discover? *I discovered that I don't need to know everything to understand a task...It can be interesting to work in this way... discovered that it was up to me to define my task.*

This shows me that they felt challenged within their zone of development and they liked this way to work. And that maybe it worked with one loose part and one more strict part in the task.

Why did you like or not like this task? *The task was free to define myself, and it was some frames we must relate to...In the start I was unsecure of what you wanted, but then I understood what to do...I liked this way of doing it.*

This confirmed my earlier observations and feedback that they liked this way of working. I could from my observations see that after some clarifying questions they worked concentrated, and when they got the rest of the task they were quiet and asked a few questions.

8.3.4 Changes

Next time I will develop my way of making tasks. I think I give them the curriculum goals and ask them about how they interpret the goals and how they might be willing to work with the goals in relation to the curriculum.

8.3.4 Significance of learning

I can see that they or more precisely, we have developed through trial and error whit talking together, and to listen to each other. ”Trygghet og følelsen av å lykkes er altså forhold som i høy grad fremmer læring”. (Hiim and Hippe 1989:35) Security and the feeling of success is what promote learning. I can agree that creating security and the feeling of master a task promote learning. Motivation increases as well when you feel you can master something.

8.3.5 Claim of knowledge

I see that they have developed from the action called swim or drown until today. When I facilitated a more gradual approach to designing their tasks, they manage this in an excellent way. They have become more structured and critical to what I “serve” them as well. Students say *it made me unsecure, but I asked and then I understands*.

8.3.6 To illustrate a fairytale

Just to show that my students starts to change their attitude, their understanding, their learning and their critical sense towards teachers I will shortly tell you about the last task I “try” to give them.

I had thoughts about the task to be inspired from the antiquity. Maybe I could lead them towards doing a box with inspiration from the antiquity. I went to the class and asked them, with the curriculum goals in my hand, a leading question. “How do you want to do this task, we should use maybe these goals....” They interrupted me with questions like this. “Do you want us to write the tasks using these goals? Yes, let’s see.” During ten minutes they decided what they wanted to do. They were divided in two with two different tasks. They wanted to illustrate a fairytale and a cover of a magazine. They joined in groups and wrote their own tasks with their own criteria for judging the task and using the goals to support the text in the task. I will as a proud teacher show you one of the results of the finishing product I got from one of the task.

The story of Little Red Ridinghood

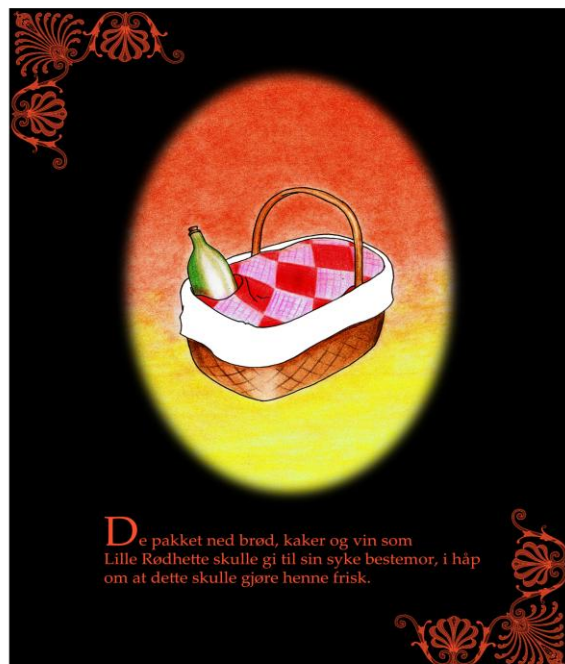
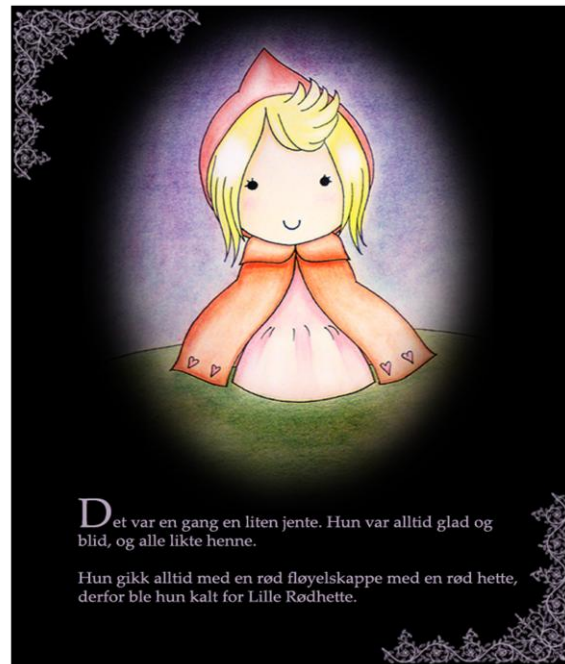



Hennes mor advarte henne.

"Husk å gå rett til bestemor sitt hus."
 "Ikke gå av stien, og ikke snakk til noen fremmede!
 Skogen er farlig."

"Ja det med ro, mor," Sa Lille Rødhette.
 "Jeg lover å være forsiktig."

Så dro Lille Rødhette fra landsbyen og var på vei til
 hennes syke bestemor

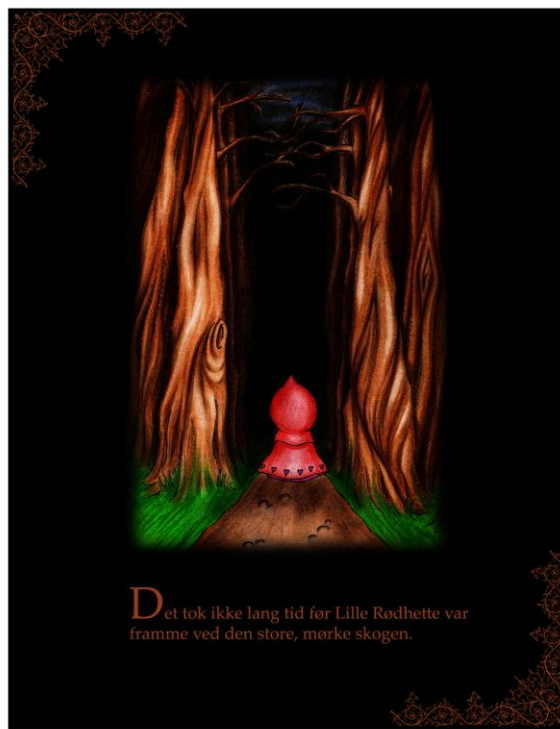

Det tok ikke lang tid før Lille Rødhette var
 framme ved den store, mørke skogen.

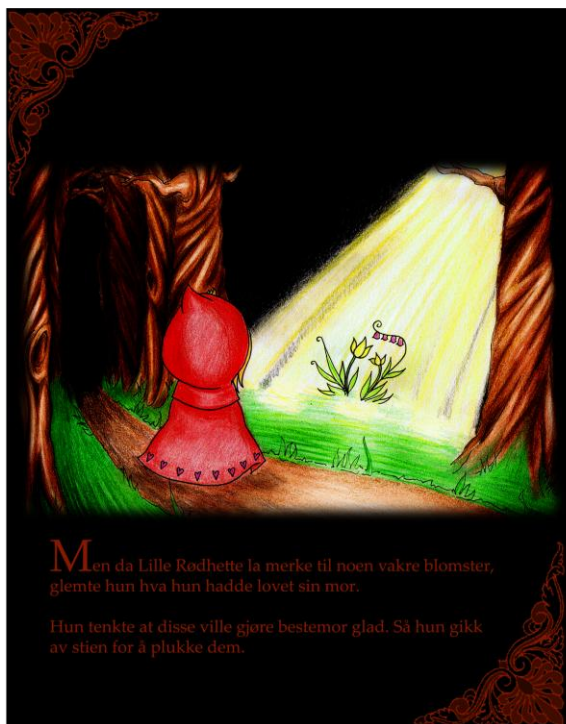

Men da Lille Rødhette la merke til noen vakre blomster,
 glemte hun hva hun hadde lovet sin mor.

Hun tenkte at disse ville gjøre bestemor glad. Så hun gikk
 av stien for å plukke dem.



Lille rødhette var så oppslukt av de nydelige
 blomstene at hun ikke la merke til en stor og
 skummel skygge som kom ut av skogen bak
 henne.

... trodde Ulven.

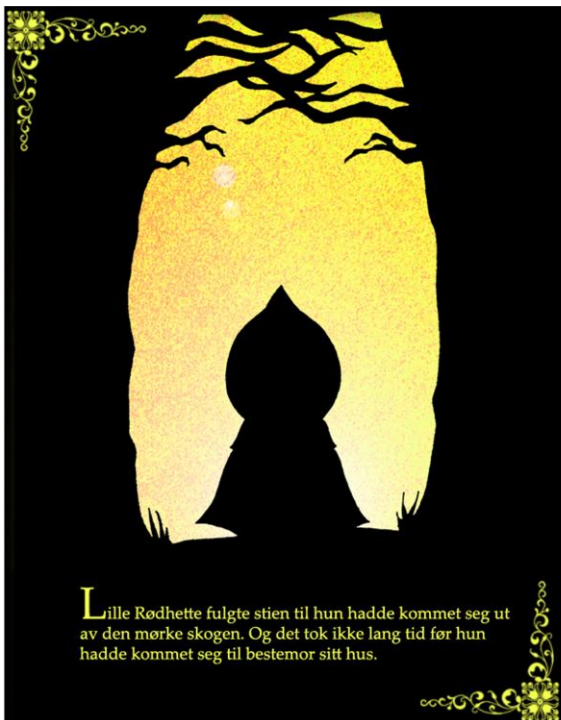

8.3.7 Summary

I have a lot of action. I have read those many times and what comes to my mind is that I can see my students and I have developed together. We use words to describe feelings and how we want things to be in the class, both written and oral. We use dialog on a regular basis to avoid conflicts and arguments. We recognize situations where it could occur and deals with it in a better way from before.

These actions are many, but I find them interesting to read because every time I find new way of seeing my students.

9 ESSAY HOW DO I IMPROVE MY PRACTICE

How do I improve my practice and facilitate for my students in order to improve their own practice?

With a focus on facilitating:

- change in attitudes
- environment
- subject tasks

To improve...making better. I have tasted this word and it does taste good, but it also tastes like effort. How did I improve my practice? This is what I'm going to discuss and illustrate from different angles. How have I improved my practice? How have the pupils improved their practice and all this with focus on attitude, environment and subject tasks.

How did I improve my practice? I used action research because the characteristics of action research is research by way of specific actions. Whitehead og McNiff (2006) say that action research starts with a need to improve your practice and that the way of presenting the problem is how to do it. I started this action research with a wish to improve my practice first and foremost by changing the class environment. I believe in Maslow who says that certain needs have to be fulfilled before we can focus on leaning and development. I will elaborate this later.

I believe that the environment has to be changed so it feels safer for me and my pupils before they are able to learn and develop professionally. This I wished to do in collaboration with my students, focusing on attitude, conditions and subject. Kurt Aagaard Nielsen (2006) says that action research is not a recipe with theories and methods one has to follow, but a view on how to do research. Ha adds that to call something action research the project has to include an action that leads to change and new insight. I needed someone to lean on in this process. I felt alone and on unsafe ground and therefore I chose to lean on Whitehead og McNiff's book Action Research Living Theory and build up this action research project inspired by them.

Action research demands processes of development, and especially social developmental processes. I see a lot of advantages with action research, especially since I have a class with a

poor environment and I wish to involve the ones it concerns and challenge them to have a say on the matter.

The starting point for my action research was that I had a concern and this concern I had on several fields, but particularly on the field concerning our interpersonal relationships. The teacher had a bad attitude and the pupils had bad attitudes. *They shouted at me and at each other and sometimes I answered them in the same way.* We simply could not go on that way.

Another side to this concerns having a desire to look into yourself to find out reasons why something doesn't work. Realizing that changes are initiated within yourself can be hard.

I was not prepared for the effect working on an action research project would have on me personally. In this process some have told me "I'm not interested in your personal growth", but to explain some of the changes that have occurred, I have to bring in a description of my personal growth. Without it there would not be a lot of change to write about.

The changes within me evolved parallel with the changes in the environment. When I became aware of the philosophy that action research is founded on, I had to rethink my own practice carefully.

I had not thought a lot about this when I started, but I've always been involved with the pupils and like to communicate with the pupils. One of my colleges told me: "it's possible that you know little about the subject, but you're really good at dealing with the pupils". I was surprised by what Whitehead says about my values shining through in my practice, in the way we associate with each other, and the reciprocal influence we have on each other. When I read this a lot of things became clear to me. My inner change and awareness had to be there before I could understand the effect of the philosophy that is the fundament of action research. Kurt Aagaard Nielsen and Birger Steen Nielsen (in Bechmann Jensen og Christensen 2005) writes in his article *Kritisk-utopisk aksjonsforskning* that you can understand action research as a distribution of dialogues about practical problems and problem solving in the organization. I therefore realize that when I took hold of the class environment and our practical problems, like for instance the structure of the tasks, when we were looking for good solutions together through dialogue and pedagogical suns, we were actually doing action research.

I now have practical experiences that have expanded my understanding of the concept of action research and therefore I will start my next project in a slightly different way. I have discovered what action research is for me and what it means to my praxis.

I wrote in the beginning of my thesis that I disliked these impudent and intolerable teenagers. They did not agree with the dream I had when I started my career as a teacher. Then I wanted to play, learn together with the small children and comfort them if they hurt themselves, in a classroom inviting to learning and social comfortable teamwork. Our world is not like that. The pupils are not small, they are teenagers, with one foot in the grown up world, and the classrooms are very little inviting. This is the world we live in and we don't like each other. When I say I want us to focus on attitude in this project, I also include my own attitudes, and the way I see it my action research process was initiated by my wish to improve my attitude towards my pupils.

I jumped into it and started the first of many actions. It was impulsive, but I discovered that the working conditions in my classes improved instantly. I now claim that when I am open and honest about how I feel and I let the students get the chance to be so too, the conditions for a close relationship between teacher and pupil are there. It's well known that close relationships create safety. We often defend relation first and then matter. This is the beginning of a big change in my world and in the pupils' world. .

Gadamer (2010) claims that open-mindedness is what separates the person who is capable of understanding from the person who is trapped by dogmas. What makes us able to do action research the way we have is a fundamental open-mindedness for adjustments of our own horizon of understanding and an ongoing struggle against dogmatic thinking in ourselves and in others. John Dewey's (1997:206-207) theories of keeping the door ajar and a hospitable thinking also supports this. Dewey claimed that taking each other seriously and being open and hospitable to each other is natural for us, and thus verifies the need I felt for being open in relation to my pupils and to involve them in the process.

I have to assert that through my actions I have improved in several ways. Even though I was insistent on improving the environments for the pupils in the beginning, without thinking of my own change. Through the strong philosophical side of action research I have become aware of my own values connected to teaching. Not only connected to teaching, but in fact in life generally. I can see that many of my own values have disappeared in all these "must do, will do, don't have time" instead of listening and taking time.

There are important factors in every relationship, also in a teacher-pupil relationship, perhaps particularly in such a relationship. One of my pupils have said: *I experienced that the teacher understood us and that she now knows how to treat us (...) I feel that Grande (the teacher) comes to school in the best mood ever.* This is a confirmation of my change, but also of the

fact that pupils can give acknowledgements, in a way that makes me feel recognized and acknowledged. We all like that. And now to the more serious side of changes and changing processes.

We who have the role of the teacher have some rounds to go with ourselves, our colleges and leadership to discuss a common strategy on what we think CC demands and how we ought to go ahead as a team when we drive the students. We ought to be engaged in human relations, but we also to teach our subjects, something many of us are more engaged in.

I think the teacher's job as an organizer is to find a balance between the social and the professional. My opinion is class environment before the professional, and I feel that I have found confirmation for this while working on this project. The students have improved their practice and reached better results since we improved the class environment and the safety in our group. Dewey writes that if school is to evolve a democratic disposition in the pupil, the teachers cannot only impart knowledge, but also have to be good examples.

Curriculums, parliaments report¹² and learning posters¹³ instruct us to make changes concerning subjects and social relations. LK-06¹⁴ emphasizes new skills and a more general competence. Grete Haaland Sund PhD.....says something about the general competence these plans demands. Haaland Sund thinks the biggest challenge in Norwegian education is to develop pedagogic leaders' competence in stimulating development of general competence and democratic working and learning environments. I feel she puts her finger on something that should have been debated loudly within every educational institution. Further she asks some interesting questions: Can we stand that pupils, apprentices and colleges develop general competence? Can we stand it if pupils and colleges think for themselves, differently than us? Can we stand it if they search for meaning in what they do? What if they find out that our teaching and leadership is meaningless? – And what do we do if they want to work with other things, in other ways than what we find important?"

This is something I will get back to later. Dewey says that the unknown makes unrest and antipathy and this is coherent with the questions Haaland Sund asks. By this I mean change in

¹² The Norwegian Parliament's report nr. 30 called Culture of learning (2003-2004)

¹³ Learning poster is a part of the school law in Norway.

¹⁴ The National Curriculum for Knowledge Promotion in Primary and Secondary Education and Training (LK06)

and development of a general competence. She thinks that it's a challenge for teenagers with the all-embracing demand teenagers are met with in relation to choose and take position to everything and everyone. The new losers are perhaps the ones who are not able to take all kinds of angles on every topic and theme and find their way in this enormous amount of information, and take responsibility for their own learning and their own lives – alone.

I can't help but wonder about the expression "alone", because I think the teacher's role is about being a present guide and instructor. In the pupils' logs after some of the actions I did, I can see that they write: *I have learned that it is important to respect each other, that it is important to trust each other. I have discovered that everyone wants a better cooperation in our class and better communication between teacher and student.*

These extracts from the logs say something about what kind of a teacher's role I have given myself. I have to put it this way since I initiated the changes that are happening. Yes, maybe it is a truth that I am no longer a contradiction...

The teacher's role today is a complex matter. The role itself has changed throughout the years. Earlier it was an occupation of status. You would stand on the roadside with your hat in your hand when the teacher came along. This is not the case today. Today the students talk with the teacher about a lot of things, also private matters. Well, in my class they do. But the role has changed, and now we are supposed to be more instructors. Society is changing and even faster than before, and the teacher's role changes at the same speed. At least it ought to, because the students are changing and so should the roles. I see that I, the teacher, have to change along with the different assumptions and needs the students have.

I feel that I know what the others are thinking, and different ways to learn. I feel that I can manage, if I try. This brings me to what the students have learned. Dewey (1916) underscores that school is a community, but that pedagogy too often overlook this and keep the students separate on separate desks with one task each. This was one of my concerns in the beginning because the tasks were very strict and governed by the teacher. I experienced, just like Dewey says, that what the students felt as a lack of community in the classroom impeded their communication and activities. They didn't talk together and were passive. I wished like Dewey to engage the students in meaningful activities with tasks they felt meaningful and where they had to learn tolerance in cooperation with each other. Purposeful activities in social frames were in Dewey's opinion the key to genuine learning. The teacher's job ought to

be preparing and arranging in a way and on several levels so it feels useful and relevant for the students. This was my intention when I started. I wanted to change our attitude towards each other, our environment and our strictly shaped tasks. I said earlier that I promote environment before subject. We have also focused on subject and on the structure of the tasks in this project.

Students' improvement

This leads me to how do my students improve their practice? Well, where shall I start? Although students have increased their professional competence, I do not know whether I have control of the “classroom monster” which is the class and all that’s happening underlying and open in the classroom. Perhaps this is called the school environment, class environment, the psychosocial environment, learning environment, learning arena. But I think that we can influence it in several ways. Not me, but we, and perhaps most of all the students themselves. Together with students, through actions, I will facilitate students to understand and discover for you how you can change and how your environment changes.

Through one of the actions called three pedagogical suns the students express themselves this way: *I've discovered that we understand each other better ... I feel that we are thinking alike in this class ... I experience that we have many similar opinions.* Students discover themselves that they are not as different as they thought, that they are actually thinking much the same and share similar opinions. To discover for you comes from Grendstad’s confluent education. He writes “to learn is to discover”. Being able to facilitate for the students to learn themselves is a challenge within the frames that the school sets, but not impossible.

First, a digression. To learn is to discover created many debates between me and my good friend and dialogue partner in this project. Within which frames would you be able to discover for you? Initially, this was good, I thought, because I stood on the side of the table that would not have to be within the scope of where and when you should be able to use this term. I was the teacher who spoke to the students. I said, “Now you can experience along the way and explore the theme. And I will guide you. Now you will find out that learning is to discover for yourself. Yes, it is only you who can discover for yourself.” The pipe had a different sound when a week earlier I was working on my master program and still was doing “discovery for me.” In this context, I think that only when one feels the case on the body, one can speak about how something works. To learn is to discover is good, but should have a

frame so that the terms of “discover” as long as that one is wrong. Then you lose motivation and that isn't good either.

Phenix (In Grendstad 1986) writes that the student who is in a position of discovery needs help from the teacher. From its more advanced analytical perspective, the teacher can guide students' work on the paths that provide the best outcomes. Moreover, he says that teaching would be a very ineffective measure if each student should try to rediscover all that usually much brighter and more experienced people had already found out ... a hallmark of good teaching is, therefore, in a program of guided rediscovery where the students discover for themselves what others have discovered before them. His discovery, however, is different from the original in that it is carried out under conditions that are adapted to students' level of knowledge in the subject and under a leadership that is based on previous knowledge. Thus, the student is spared for unnecessary mistakes and frustrations. This is completely in line with what Vygotsky says, that it is not necessary to discover all the new by yourself, one can use tools so you are learning faster.

Back to business. To learn is to discover is not impossible, and I have many actions that can show this. Students learn that they have similar challenges and they like to learn. They learn that they can achieve something with their own efforts. They learn that the teacher cares about their learning. They learn what student involvement is. They learn democratic processes. They learn that they must contribute to the class environment. They learn about respect. They learn about teamwork and communication. They learn to have an increased understanding of each other. And all this they have found themselves, with some adjustments.

Being able to learn something is about having met a need. I mentioned Maslow earlier. Maslow's hierarchy of needs is such a device that can explain this. It assumes that humans are motivated to satisfy their needs or reduce the tension or discomfort created by not satisfied needs. Skaalvik and Skaalvik (2005) claim that motivation is considered a result of that important needs are not met. I have already said that I am concerned with to learn is to discover and I think that knowledge creates thirst for more knowledge. I see the necessity of certain needs to be covered before one can start to learn is to discover for you. I will briefly say something about this pyramid of needs, because I see that it can be an explanation of what's happening in our class. As I will return to later.

Maslow's theory distinguishes between two kinds of needs, lack of needs and growth needs. Lack of needs consist of basic needs that all need to get satisfied. There are four such groups: physiological needs like food, water, heat, need for security and safety, need for belonging and love, and needs to be appreciated and to appreciate yourself. This lack of needs may be critical for a person's physical and mental well-being. The motivation is to get them met before one can concentrate on covering up the growing needs. Growth needs consist of: the need for knowledge and understanding, aesthetic needs and the needs for self actualization which is to develop their capabilities. The growth needs can never be satisfied. I have said earlier that knowledge grows a thirst for more and Skaalvik and Skaalvik conform this. Many of the students have responded in their logs *I'm hungry*. I worked on the themes in their lunch and I see that the need for food was not satisfied and that they had a lot of focus on their hunger. But when I first realized that this needs to be covered and facilitated for, there were other things happening in their logs. Then I got confirmation of their learning. Students write, *I feel I can achieve something with others.... I have learned what student participation is.... I've learned that respect goes both ways between the student and the teacher.... I will respect teachers and students more.*

It is at the top of the pyramid we adopt "to learn is to discover." Then you want to develop talents, knowledge and skills. Food we need before we want to learn, confidence and good relationships create good environment, recognition of different reasons creates motivation and a basis for "to learn is to discover." It is not difficult to see that you have to satisfy the deficiency needs before you can start developing your talents. I said during my digression "to learn is to discover" that it is only when we know the concept on the body that one can speak about the case. Then you have at least experienced something. When you reflect, evaluate and systemize your experience, you have started the process from the experiences to learning. When you get to meet your own basic needs, the desire for more knowledge increases. And here we are at an important point, this is what has happened in our class.

I often advocated, when I first started talking about my project, relationship before the case. To create a safe and secure relationship, because that is in a relation with a good environment was also important. There was also a wish in me to create confidence in the class because many felt that it was unpredictable with so many discussions and arguments as previously described in the project. One can recognize these tensions as a stomach ache and headache, and several students complained constantly over such pain. This is actually many of the same

symptoms as in cooperation and conflict, another of the actions we have initiated. Students wrote on notes what they thought when they saw the word conflict and then we did the same with cooperation. The fact that they came to the conclusion that these words, concepts, were very similar surprised me. I also think that surprised them. Afterwards, they said this: *It is not easy for everyone to be friends with everyone, but it is possible to be good classmates.... let others speak so that they dare to speak their opinions...it pays to listen to others before interpreting things the way you want, it is not always the facts that you yourself think.* These students are 15 and 16 years when they discover such insights. I'm not sure if I had this insight when I was their age. I see that some in the class are good at dealing with both, but many need to find out the differences and similarities so that they can recognize emotions and thus change their patterns, particularly in relation to the conflict. I believe that they have improved their practice on this area as well.

Subject

I show through my concern and my description of the early meetings with my class that we needed a change. I was worried about myself and had no knowledge or adequate words to describe what wasn't good. I was concerned about the environment in class and had an intuition that the tasks we gave to students did not work right in my opinion. They gave little room for own thoughts and reflections. I reminiscent of Maslow's hierarchy of needs again. Safety lies near the bottom of the pyramid and is therefore a pressing need that must be met before one can begin to work with the issue or task. Then comes the need for belonging. We must create good relationships in a safe frame so that we can get a good environment in the class. The upper stage of the deficiency needs is the need for self-worth and recognition. In my actions, I want to facilitate to be seen and taken seriously. At the same time they need to get tasks they mastered so that they can achieve recognition in this way too. Motivation is related to recognition. And Skaalvik and Skaalvik (2005) believe that students who receive recognition from the teacher are motivated and thus provide in school, but I got the rule (the student), which confirms the exception.

This is due to how I perceive the need for changes in the strictly-shaped task we gave the students. I wish to have critical and convinced students who do respond *why this and why don't we do this* when there is talk about preparing assignments, how the teaching is or working with curricula. How self-esteem, motivation and coping are linked in a good go together with a good learning environment. The learning environment focuses on factors such

as responsibility for their own learning, assessment, social environment, adaptation, social comparison, structure and oversight. I will mention the ones I've been interested in in my actions. In relation to the action Swim or drown, I would say that the challenge of the proximal zone was big. But for the pupils to feel secure in the learning situation, they must have a certain structure and overview and clarification of expectation. Skaalvik and Skaalvik (1996) state; that a clear structure doesn't deprive students of initiative, independence and responsibility for their own learning. I believe the structure helps students to use their initiative, responsibility and autonomy within certain limits. I lean on Phenix again and thus spare my students of much of the frustration I have known in my master's. Not everyone learns best under pressure, and I think destructive frustration does not promote learning for some. Students are certainly used to it from lower grades. But the goal must be from the very strict framework that gave no room for their own thinking and reflections to challenge students' proximal Zone to find a shape and structure that fits the context. In this action, I think the challenge went wrong even though we learned a lot, both the students and me. The student has answered the logs like this. *I learned to think for myself..I didn't understand anything, but we talked and I had to think for myself.* Yes, something good came out of it even though only two of fourteen handed in a finished product. Dewey said that it is the active student who learns. If the challenge is too big, as it was in this task, I think the students respond with passivity because they do not see how to resolve the issue. Thus, nothing happens and they cannot deliver a finished product.

Responsibility for their own learning is also enshrined in the CC. There is a wish for the students to take responsibility for their own learning. But it is said very little about how the student should be able to take this responsibility. I have said that my students have a sheep mentality after 10 years of elementary school, it is not coherent with responsibility for their own learning. There are many who believe that learning is an active process and that the process must be carried out by the one who learns. In cognitive psychology that points out that new experiences are interpreted and given the light of established knowledge structures. This requires the pupil's active participation. In relation to how I do this as a basis when I want the students to write their own tasks within a framework of structure, I do believe that I facilitate for a good learning environment. The student will have a stronger sense of belonging to the task and it is known that having ownership of tasks increases motivation and thereby improve the learning environment.

Co-determination has something to do with the student role. In one of the actions we talked about the roles, the different roles we had in the course of a day. We would like to have talked more about it, but were interrupted by a discussion about respect. Participation has to do with democracy and respect has to do with democracy. Today I see that we should use the next meeting to complete the rest of theme. Next time I have to be better at grabbing and collecting the threads that are lost, because the effect of initiating something disappears when you do not get through the lesson with you theme. Now this isn't entirely true for the purpose of this action, we all got a greater understanding of the roles we alternated between and that we may not have the right hat on at the right time. I have initiated a process, I've been facilitating and initiating, planted a seed. I can't do anything but wait and see if the seed develops. I do not know what is happening inside each individual student. Well at least not without asking first.

We talk about the need for the student to be motivated and take for granted that the teacher is. It can't possibly be right. I think, and this is an assertion, that without replenishment and development you will be very "professional" without actually doing your job. Yes, you are engaged in teaching, but the job is so much more. Teacher's role today is a very demanding role. We have received quite a number of claims down on our heads from the ministry, leadership, colleagues, pupils and parents and not least from ourselves. The last requirement is perhaps what leads to the greatest change.

The requirements on the teacher role are diverse. The general part of the CC is divided into the seven human types, so we can be a complete human being. In some parts there are many demands to the education. I say something about the education now to make visible those requirements for teacher and student today. "The training aims to equip children, young (...) to meet life's tasks and challenges with others. It will provide each student's skills to take care of themselves and their lives, while profits and willingness to stand second bi. "(CC: 15) But what does this say about the teacher's role. Have we gone into the fundamental values, human vision and the role of teacher an educator receives. We are instructed a great responsibility that I think is a little obvious in the CC. Implicitly you could read that it takes an awful lot of the teacher's role today. "The final goal of education is to encourage the individual to realize himself in ways that will benefit the community - to nurture the humanity of a society in development." (CC: 50) I connect this with the questions that Haaland Sund asked earlier in the discussion. She speaks of overall management skills and set up questions like this. I

summarize: *Do we bear that others have a comprehensive knowledge, thinking for themselves and even different? Do we bear that they seek meaning and find that they will do things differently. And will work in different ways than us?"* This is not consistent with the holistic human being. And it's not just the student who will be comprehensive. But these are good questions and raise doubts about the Norwegian School as I know it today.

Skaalvik and Skaalvik (1996) write that self-assessment is used about students' skill and their own performance and is about the students' general feeling of doing well in school. This is, of course, along with the mastering that students feel in relation to some tasks the student must solve. Moreover, they say that we are influenced by significant others when it comes to these things. What is important is that significant others can be the teacher. And that there may be an environmental impact that can change students' self-assessment and mastery and thus students' motivation. But if the environment can affect our self-assessment, can the poor self-assessment affect the environment? This is a consideration that is exciting compared to our poor environment. Can this apply to teachers too? That they must feel mastery in their jobs? I would say a loud yes.

In relation to the changes that must take place in our classroom these factors affect each other mutually. Others have an impact in relation to our own perception of us, this can affect our attitude in a good or bad way. And our self-perception is influenced by many factors. In relation to teacher-student attitudes toward themselves and others this must affect the class environment. When I expressed my concern in relation to the environment, I've seen that students with poor self-perception, attitudes and motivation creates a bad environment, but it is also so when the teacher holds the same bad combinations that the environment will be affected in a bad way. I observed that changes start with me and can develop into something good.

This also leads to changes in the teaching role. I've only mentioned this earlier in my thesis. My role as supervisor will increase and I need to change the role in line with students' assumptions and the need for dependency. In such changes dialogue is an important element. These processes of change can often lead to misunderstandings between teacher and student about the student's level of independence. I have said before that I use to answer my students with questions so that students can reason their way to the answer themselves. Telhaug in Skaalvik and Skaalvik (2005) says that the teacher role is called the teacher as technician dialect and dialogue partner. I would say that my teacher's role has changed from being a

more informant's and the controller's role to become more of a dialogue partner. I have experienced drastic changes in my teacher role. Today I facilitate to a much greater extent for my students to discover themselves through dialogue and inclusion. I want to say changed from an advisory role to guidance role, but I feel that my earlier desire to have total control can be called an informant and the controller role. What roles you take is based on teacher experience, education, personality, confidence and the teacher's views on learning and teaching. For myself, I will also add that the normative culture of the school is of importance. One can encounter great resistance if one holds the active teaching role if they have the most informative and controlling role.

I have answered my research question: How do I Improve my practice and facilitate for my students in order to improve their own practice. I had focus on facilitating attitude, environment and subject tasks. Together we have improved our attitudes, the environment and subject tasks.

10 HOW DO I EVALUATE THE EVIDENCE-BASED ACCOUNT OF MY LEARNING?

Researching involves a learning process from you start the research project until you finish the project. You investigate your own practice which is a large social practice. When you write the text about your research it involves a learning process of textual communicating which is an individual practice. Doing action research is both a social and a individual practice.

My thesis is a written text and it will communicate to you through the narratives. As Whitehead and McNiff (2006) write, the thesis is communicating with you via the medium of written language. I will use Habermas' criteria for social validity because writing and reading a text is a form of socially orientated communication action in Habermas' term.

1. Comprehensible – Is my account comprehensible?
2. Truthful – is my account truthful?
3. Sincere – is my account sincere?
4. Appropriate – is my account appropriate?

10.1 Comprehensible – Is my account comprehensible?

I have, as I said earlier, used a language that everybody can understand. I do not use difficult words which I don't explain. I have in no way had intentions of innuendo and therefore I don't use such techniques. I have tried to clarify my position, I work as a teacher in a class with a poor environment. I say something about how my workplace is with my colleagues and with the frames I had then. I see today that the frames have changed for the better and that it helps to spread my "message", even if I felt opposed. I think I speak to your experience by dealing with daily problems at school in a class and by dealing with humans. When you work with people you meet different problems, but a lot of them are in a way similar to each other. The problems that I have been writing about are my concerns about a poor environment in the class, a concern for my own and my student's attitude towards each other and the design of the task which was given in the class. Do the students learn and how do they learn, are they motivated and how do I make a better environment for us all in the class.

I am writing about changes in me, with me and my students, and I think these problems and worries are recognizable.

I have respected the academic conventions, used references correctly and ground my theory from appropriate literature for me. I have also structured my thesis so it is coherent with correct grammar. It consists of parts, but all parts together make a nice coherence when you read it.

I let my passion shine through and do not reinforce prejudice. Rather to the contrary. I think I lose some prejudice in relation to myself and of course for my class. I didn't have a good view of the students when we started the year together, but now I realize that certain circumstances gave the students a sheepmentality and that it's possible to lead them out of that. I also realize that a fair and square relationship needs to be a base before you can start serious changes.

Maybe I haven't been able to channel my disputes to the right authorities. Whether I'm talking about the management of the school, my colleagues or other unpleasant situations I have had to be in. I have not been able to stay in this for various reasons. I chose the easiest way, so I have continued smiling and walked the other way. Such situations are unpleasant and sometimes there has been great resistance. But today I realize, like I wrote earlier, that the more you talk about what you think influence your learning, the more people listen. And I am satisfied with that.

I have tried my very best to let my actions and what I want to investigate talk for me and by this let the meaning emerge from within the text. I think I do this as well.

10.2 Truthful – is my account truthful?

Do I make claims without evidence for my claim? No, I don't. I have logs which I used as an evidence base and I support everything I mean or claim with logs and with theory as well. I use my logs anonymously because I don't want my students to be recognized. I hope I don't put my scholarship as a doctrine, but I do believe in what I have learned after this project and I do believe I have increased my knowledge after working with an action research project. I speak of what I have learned and what I believe in and I try to remember that I do not possess the only truth. When I'm talking about building up an intellectual self-defense against any influence, I must say I am influenced by Whitehead and McNiff's philosophy of making my living theory. I can see different problems in different ways because of an increasingly open mind. And it turns out that when I open my mind it has a contagious effect on others as well. The book *Action Research: Living theory* has been an inspiration and challenged me on several levels. I even try to be more cooperative in my school community with my colleagues

and with my students. This project has inspired me to do so and maybe this engagement is a process of cultural influence at my workplace.

All the way throughout writing and doing my claims I have been truthful.

10.3 Sincere – is my account sincere

I have tried to be sincere throughout my whole thesis. In relation to my concerns, towards my students, whom I want only good things for and in relation to improving our environment in class with the means I had available. I used actions to increase the consciousness of my students when it comes to reasons why they chose the same program at school, and also to increase consciousness about why they thrive and how and when they learn best. I made them aware of differences and similarities, and that we can accept many things if we just respect each other for each other's learning and the teacher, not the least. I have tried to increase the trust between teacher and students so that a fundamental relationship builds the ground for other changes. I've tried to make my values trust, fairness and honesty be shown through my behaviour and in my teaching. Because being conscious of how one affects the environment around you is important. That's what it's all about.

I haven't been so occupied with other traditions, but in a way they have been occupied with me and my meanings. When a more traditional environment at school told me that action research wasn't research and I couldn't be a researcher, I thought I shouldn't deal with that issue.

And again it is possible that I have presented this text as the only truth. But I know that it's not and hopefully this thesis isn't like that. I have written earlier that I tried to be a little humble. In fact I don't possess the only truth, but sometimes I find it difficult to change myself.

Maybe I have overlooked, in my text, evidence of activity that is not a good activity. I have not omitted anything about negative evidence or said or done anything to hide what's going on. One example is what the students said about me. I was grumpy and didn't listen and basically was not a good teacher. I am not so tough, so it did affect me. Anyway I may have overlooked other important and interesting incidents in my thesis. This is not on purpose.

10.4 Appropriate - is my account appropriate?

When I write a pedagogical text, an action research in education, we can challenge the normative background for a culture whose norms are established. As Habermas (1976) writes, these norms are held in place by invisible regimes of power. I will not go further into a discussion about this. I just want to remind the reader that even if these power constellations exist, it does help talking about my own research little by little. I will continue sharing my knowledge and thereby helping to grow new knowledge with others. I often think that it is in such rigid environments that there is no living theory, only theory.

In another environment with other normative backgrounds, such as HIAK, there is no such problem. And you feel confident that people in the environment listen to what you say and discuss the matter as equals.

I think my thesis is appropriate in every way it should be. I am maybe a bit hush sometimes, but I said nothing that I can't stand for. And I would never write anything to make a fool of myself, my colleagues, my workplace or the place where I study.

10.5 Can we believe the story that is told?

I have been talking about my text, whether it is technically good. Now it's me I need to evaluate, so that the story can be believed, and it's about establishing moral validity. Am I trustworthy? Have I shown through my thesis that you can trust me? Yes, I think I have. By identifying my values as the living standards by which I can judge the quality of my work. I think I can be trusted because my account is grounded in evidence of learning, and that the learning can be understood in relation to my values which are trust, fairness and honesty. I show my evidence as fair and accurate as I can, I do not hide anything even if it's not to an advantage for me or my practice.

10.6 Summary

I use Habermas' criteria to evaluate my work as a thesis and a written account. Is my account comprehensible? I use a language which is easy to understand, I let my passion shine through in every action I do. I mean my account is truthful and sincere as well. And of course it's appropriate for the normative background.

11 HOW DO I MODIFY MY CONCERNS, IDEAS AND PRACTICE IN THE LIGHT OF MY EVALUATION?

When I started to do what I believed was an action research project, I did that out of concern. I had concerns about my student's attitude towards me, my attitude towards them, about our environment and about the strict tasks I gave them in my subject. I had the opinion that my students had a sheep mentality and that it was outspread in the class. And that prevented them from being critical and conscious young people.

I also didn't recognize that my values were denied me at my workplace and I didn't understand the concept of living theory. I wanted to change all this and I wanted to do that with an action research project. Thus I didn't fully understand that concept either. Next time I will do my research differently. I will say something about this later.

11.1 Modifying my concerns

Today I see the consequences of my concerns when I acted upon them. Back in the start of this project I was determined to improve my class' environment. I was sure that I had the answers to all the questions and jumped into an action research project. Today I would have investigated more before taking action. I would be more aware of the possible results of the action. I would have discussed with my colleagues and management so that I had received more support when I was to carry out actions. It's about doing a pre-project that ensures the quality of the questions. My concerns would maybe change and evolve, perhaps even fade when they could be shared with others and I heard others' opinions.

11.2 Modifying my ideas

I was intrigued by action research before I met Jack Whitehead, but after listening to him I got more intrigued by this way of doing research. I didn't fully understand the action research method, but jumped into my first action which was on impulse because I saw the need of talking to my class. I assert I wouldn't learn so much if I haven't jumped into action research. Later I did my planning for the actions well.

Next time I will have straight forward and clear research questions. I will have prepared what topics that may help me in relation to the research questions. I will also be more aware of the log questions and what I may achieve with them and why I use them. I know why I used them in this project too, but I was unsecure of whether the questions were good enough and thought

I changed them too often. One reason for that is that I do not like to write the log myself. Next time I will try them on my validity group and friends to secure it work well

Now that I understand action research better and have been through the 10 questions from Whitehead and McNiff (2006), I would probably have been even better in the next project at understanding and working with these issues. I'd spent more time trying to understand or to put words to the concept ontology. I like to read about philosophy and Habermas, Polanyi, Gadamer and Dewey as well. This I had to give up at this time because I didn't have enough time. I discovered that such difficult questions must be discussed, read about and then brooded inside my brain. So I had to read and speak and brood again. And when there isn't enough time...

11.3 Modify my practice

I would certainly discuss more fully from the start with everyone, so that what I was going to do became more harmless. Then I would have been steadier in talking about what I believed and was passionate about, and not so easily rejected by others, which I felt I was sometimes.

I also think that to continue this work further now that the understanding between students and teachers has increased, is good. Such a process is an ending process. And you change, evolve for yourself and with others. And it's good that we can use dialogue to share what we are able to and know so that the development doesn't stop. I often see that there are many issues I can raise in class. We have new students who need to break a school code, a class code, and I do not think it is easy to find one's place in a class that has worked its way through so many problems. Many structures have been laid. My job is to break up the structure and place it in a different and better way.

I know one thing I would have done different. In some of my actions we got interrupted by arguments between students. I can see the use of pulling the different opinions together around the theme we were working with. Loose ends can sometimes be good, but not in this situation where it would create more insecurity. The result of this isn't quite clear to me yet. I have, no matter, sown a seed that sprouts, and the student's are able to learn, as they discover for them, what's going on.

11.4 Do my research go on?

I am planning new actions later this year. I will explore my values and put focus on my student's values as well. I think this is important especially because I see what it did to me when I did explore this in my thesis. We need to do this in the community we have today. I will also explore the multimedia form in my work more often. It can be useful for all of us to see how we affect others in the way we act. I think some of us need to be aware of this. I will for sure try out more of the SØT-model and my dream is to write a book on how to improve students and the teachers in first grade.

It is a lot of other medium which can be used, blogging for example. The youths use this media often and it is easy to communicate through this media.

11.5 Summary

How do I modify my practice and my ideas? I will try to do something's better, evaluate some actions, and try other concerns and more action research. I have outlined my way further and I think this is a good way to go. Doing action research is a relevant way of working wiyh a blended whole in school. I wanted to improve my practice and facilitate for my students to improve their practice. I have done so and with good results.

BIBLIOGRAPHY

Bachmann, Kari and Haug, Peder (2006): *Forskning om tilpasset opplæring*, forskningsrapport nr. 62, Volda: Høgskulen i Volda.

Dalland, Olav (1997) *Metode og oppgaveskriving for studenter*. Oslo: Universitetsforlaget AS

Gadamer, H.-G. (2003): *Forståelsens filosofi: utvalgte hermeneutiske skrifter*. Oslo: Cappelen.

Gadamer, H.-G. (2010): *Sannhet og metode: grunntrekk i en filosofisk hermeneutikk*. Oslo: Pax.

Galtung, Johan (2006): *Johan uten land. På fredsveien gjennom verden*, Oslo:Aschehoug & co

Gordon, Thomas (1979): *Snakk med oss lærer*. Oslo: Dreyers forlag

Greenwood, Davydd J. and Levin, Morten (1998): *Introduction to action research: social research for social change*, Thousand Oaks California: Sage Publications

Grendstad, Magnar (1986): *Å lære er å oppdage*, Oslo: Didakta Norsk Forlag AS.

Habermas, Jürgen (1987): *Lifeworld and system: a critique of functionalist reason*. Boston, Mass: Beacon Press

Habermas, Jürgen (1984/1997): *The theory of communicative action, vol.1-reason and the rationalization of society*. Original 1981, translated in 1984, this edition printed 1997, Great Britain Ltd, Cornwall

Habermas, Jürgen (1976): *What is universal Pragmatics?* Edited by Maeve Coock (1998) *On the pragmatics of communication*. Baskerville. Wellington Graphics. USA

Hartviksen, M., & Kversøy, K. S. (2008). *Samarbeid og konflikt: to sider av samme sak* Bergen: Fagbokforlaget

Hiim, Hilde and Hippe, Else (1998): *Læring gjennom opplevelse, forståelse og handling*,Oslo: Universitetsforlaget A/S

Hiim, Hilde and Hippe, Else (1998): *Undervisningsplanlegging for yrkesfaglærere*, Oslo: Universitetsforlaget A/S

- Holme, Idar Magne and Solvang, Bernt Krohn (1991): Metodevalg og Metodebruk, 2.utg. Oslo: Tano A/S
- Imsen, Gunn (2009) Lærerens verden, 4 utg. Oslo: Universitetsforlaget.
- McNiff, Jean and Whitehead, Jack (2009): Doing and Writing Action Research, Los Angeles: SAGE.
- Milne. A.A (1926): Winnie the Pooh
- Sartre, Jean-Paul (1993): Eksistensialisme er humanisme, 2.utg. J.W.Cappelens forlag AS.
- Skaalvik, Einar og Skaalvik, Sidsel (1996): Selvoppfatning, motivasjon og læring. Oslo: TANO AS.
- Skaalvik, Einar og Skaalvik, Sidsel (2005): Skolen som læringsarena. Selvoppfatning, motivasjon og læring. Oslo: Universitetsforlaget AS.
- St.melding Nr. 30 (2003-2004): Det kongelige kirke-, utdannings- og forskningsdepartement. *Kultur for læring*. Oslo 2003.
- Schön, Donald A. (1983): The reflective Practitioner: How Professionals Think in Action, New York: Basic.
- Sund, G. H. (2005): *Forskjellighet og mangfold - muligheter eller begrensninger for individ og arbeidsplass?: et aksjonsforskningsprosjekt med studier av læring i daglig arbeid, gjennom medvirkning, demokratiske prosesser og interessedifferensiering*. Roskilde Universitetscenter. Forskerskolen Livslang Læring, Roskilde.
- Tiller, Tom (red.) (2004): AKSJONSFORSKNING I skole og utdanning. Kristiansand: Høyskoleforlaget AS.
- Tveiten, Sidsel (1998): Veiledning- mer enn ord. Bergen: Fagbokforlaget A/S
- Whitehead, Jack and McNiff, Jean (2006): Action research: Living Theory. London: SAGE.
- Aagaard Nielsen, K., & Svensson, L. (2006): Action and interactive research: beyond practice and theory. Maastricht: Shaker Publishing.

Andre kilder:

<http://ejolts.net/node/7> (15.0.10)

<http://en.wikipedia.org/wiki/Ontology> (01.04.10)

<http://intuisjonsskolen.no> 09.0410

http://www.udir.no/upload/larerplaner/Fastsatte_lareplaner_for_Kunnskapsloeftet/prinsipper_lk06.pdf (16.03.10)